

Sherpa M43

Intelligent Solar Controller

Full installation and use manual

Full Guide



Detailed installation & use guide

Solar Thermal – The natural form of pure energy

In 90 minutes, the sun irradiates the earth with the energy that humanity needs for an entire year. This in itself is an exciting element to understand the amount of energy lost unexploited and could solve the energy problem universally and entirely.

Solar thermal is the process of direct conversion of solar energy that reaches Earth in the form of radiation to heat and its storage in properly insulated stores that often contain water.

Either in the form of solar water heaters or in the form of forced circulation systems, solar thermal systems are characterized by the immediacy in energy conversion, which makes them ideal in achieving exceptional efficiency levels that far exceed even the most modern photovoltaic or other forms of clean energy.

They have long been and continue to be wise examples of the use of the most efficient and rational form of clean energy that has little environmental footprint and is made from raw materials that are almost entirely recyclable.

Features

- Illuminated graphic display
- Multilingual menu
- Handling via RotorFlex rotary-push button
- Temperature measurement and imaging -40°C...+300°C.
- Control the collectors' circulators
- Auxiliary source control (e.g. burner, electrical resistance) with time program
- DHW recirculation control
- Ability to charge up to 3 containers with or without priority
- Driving circulators with speed control (according to standard DIN IEC60469-1)
 - PWM1
 - PWM2
 - iPWM
 - Profile C
 - Profile Solar
 - Profile Heating (Grundfos UPMML, UPMXL, UPMML geo, UPMXL geo, SOLAR PMXL) etc.
- Collect data from the PWM output of the circulator
- Error logging record
- Memory self-correction function (AMR)
- Drain-back function
- Vacuum tube collector operation
- Statistics recording
- Measurement of thermal gain/stored energy
- Thermal disinfection (active and passive)
- Wireless temperature data transmission (AirLink)
- Lightning protection.
- Adjustable anti-freeze protection
- Manual output control

Use

Small and medium-sized thermal forced circulation systems for full control of preparation and management of domestic hot water.

Safety Instructions

The device has been designed in accordance with modern specifications and meets the appropriate requirements to operate without problems for years. All safety instructions for such devices have been taken into account in its design. Please read this installation and use guide carefully. Before taking any action, make sure you take the necessary precautions and fully understand the consequences of your actions. If you have any question, do not hesitate to contact the manufacturer.

- The installation must be done by a qualified electrical professional authorized to perform operations according to EN50110-1.
- The device can be used as a control device but never as a safety device for an installation.
- Do not use the device in applications other than those for which it has been designed and listed above.
- Do not use the device in applications critical to human life.
- The device is not waterproof. Place it in a place that is not wet and not affected by weather conditions.
- The device is not a measuring instrument.
- Do not exceed the operating specifications as listed below for any reason.



The device stores information about the duration and how it is used. The manufacturer reserves the right to use this information solely for its internal use if it is returned for any reason to its laboratories.



The manufacturer shall not be liable for any damage or damage that the device may cause during its operation to installations, devices or systems with which it cooperates, connects or controls as well as to areas in which it is installed.



The technical characteristics, capabilities and operation of the device as described in this leaflet may be modified without notice.



The drawings presented in this manual are indicative. The completeness and integrity of the projects to be implemented shall be subject to the sole responsibility and cognizance of the engineer responsible of the project concerned.

1. Installation

1. Installation - Support

The device can be mounted on a wall or in a hydraulic station recess with the appropriate dimensions. On the back side are provided suitable holes that are 126mm apart so that it is simple and easy to support and align. Carefully select the point so that it does not get wet and there is enough space for the required wiring.

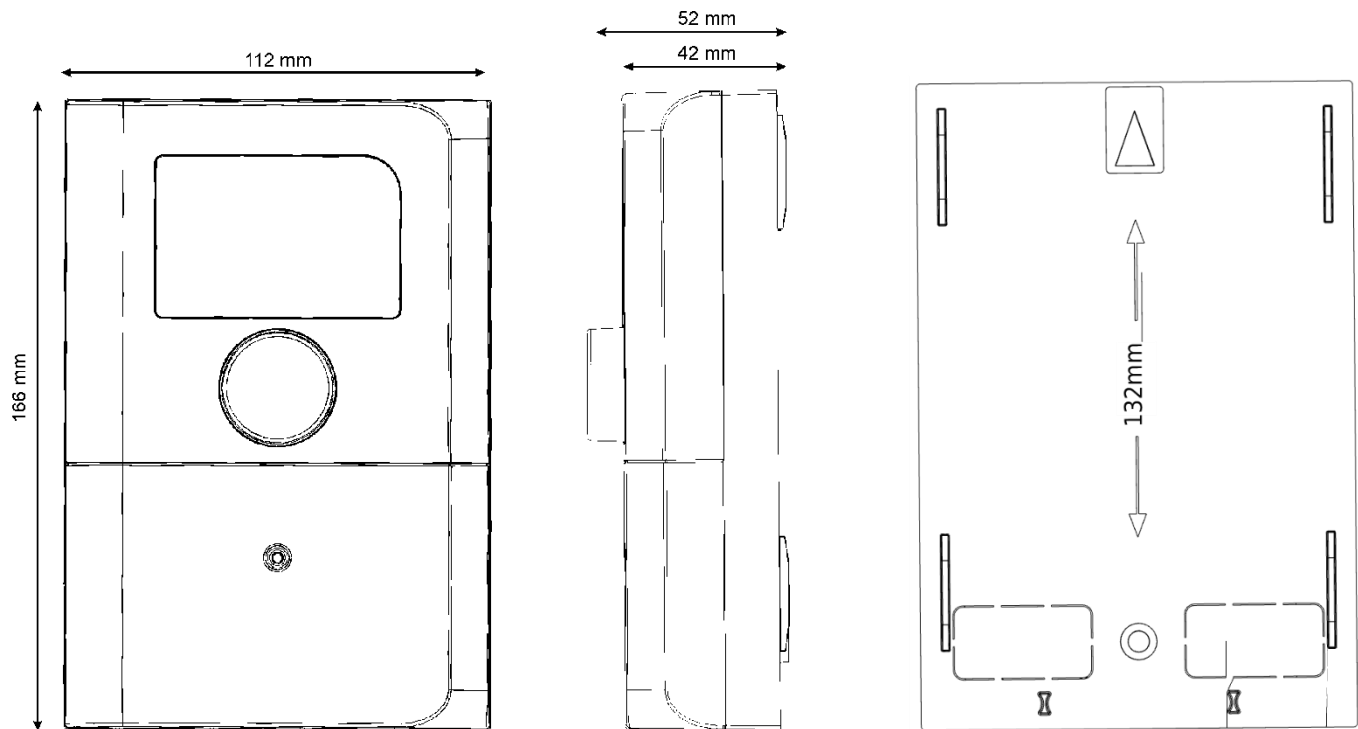

Figure1

2. Electrical connections

During installation switch off the power supply. Choose cables of appropriate cross section depending on the electrical current and the voltage to be applied. The device has heavy-duty cable terminals for easy and safe installation. Do not overtighten the terminals. Carefully study the connections before you begin.

The cables can be fed through the lower side gromets or by removing the pre-engraved windows located at the bottom of the rear of the junction space.

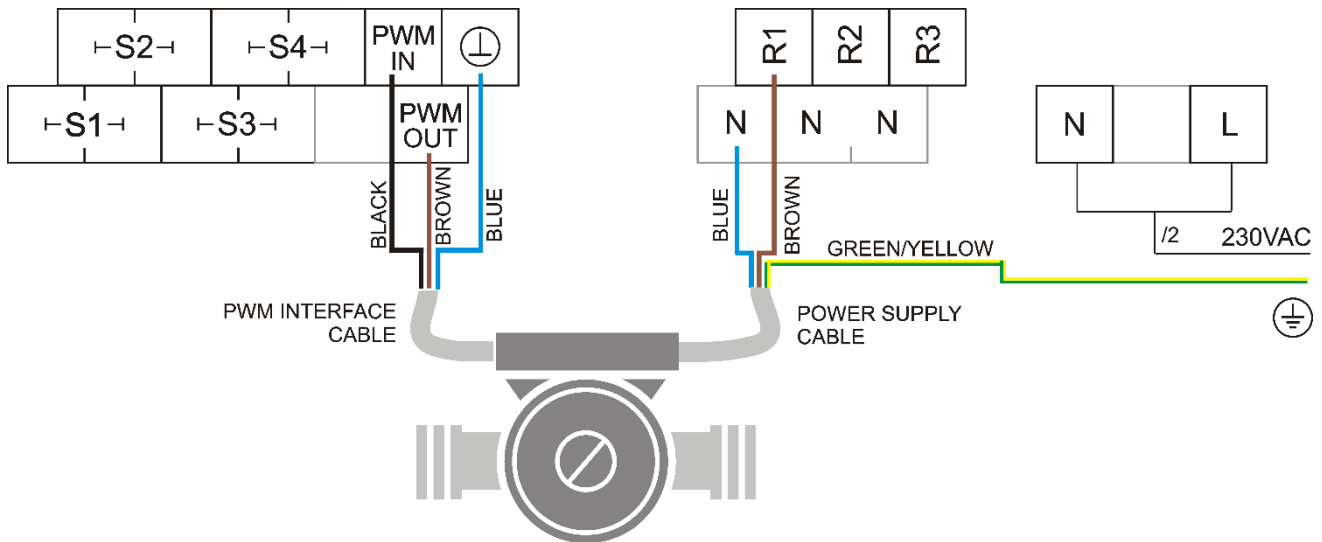

Figure2

Place the sensors in a specific diameter probes to properly measure the temperature and perform effective control.



The sensors must be of type PS301k0 (PT1000).



The maximum device-sensor distance is 40m. The connection can be made with a simple two-wire multi thread cable e.g., 2x0.75mm².



Use independent cables to connect sensors or PWM signals and relays or power voltage. The use of common cables that simultaneously pass low-power signals and high-voltage or current currents affects the performance of the device.



If your circulator has a speed control input according to PWM (DIN IEC60469-1) e.g. Wilo Yonos Para, then the relevant cable must be connected to the PWM OUT (brown) and (Blue) ⊥ contacts.



If there is a black conductor on the speed cable of the circulator, it is connected to the PWM IN contact.



The maximum transmission distance of the PWM signal to the circulator is 3m through a single, multi thread cable of 0.5mm² or greater.



In systems with more than one PWM circulator (e.g., plans No6, No7, No9, etc.), the circulator speed inputs are connected together to the PWM OUT (brown) and (blue) ⊥ contacts. The speed setting is proportional if a single circulator is in operation and at maximum speed if more.



In systems with more than one PWM circulator (e.g. draft No6, No7, No9, etc.) the output of a single circulator (Black Conductor) PWM is allowed to connect to the PWM IN contact and will only monitor its condition.

The device accepts and produces PWM signals according to DIN IEC60469-1.

After the installation is complete, install the front panel cover. When operating the device for safety reasons only the front view must be accessible to the user.

2. Operation

1. Device description

The device has an illuminated graphic display and rotary push control (RotorFlex). All manipulations and adjustments are performed through them.

If it is powered for the first time, it will ask you to enter the contact language on the date and time. These first changes are made by turning the control to select and pressing to confirm.



Figure3

It will then display the display containing the QRcode corresponding to the detailed guide you hold in your hands. After showing the QRcode screen for a few seconds or simply pressing the controller will start operating the device according to the factory preset.



Figure4

2. Setup

Pressing the control briefly switches to the "Main Menu". From this you can choose one of the available sub-menus that are distributed according to the content of the functions they manage. These sub-menus may provide access to parameters or other sub-menus.

By turning the control, we scroll through the available options, pressing briefly,

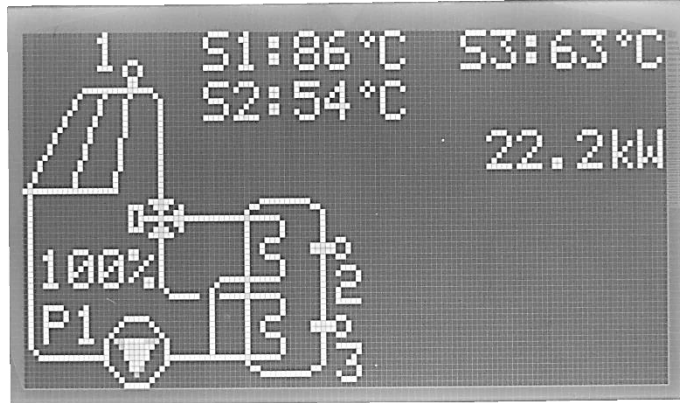

Figure5

confirming and pressing and holding, returning to the previous menu or submenu. The return to the previous menu or sub-menu and generally the output of the device from the setting mode to the operating mode will be done anyway and on its own after a while if the control is not pressed for some time. At the bottom of each menu screen or sub-menu, the permitted selection, confirmation and return uses provided via the control panel are displayed.

Table 1

- ● +	By rotating we select
☛ = OK	Pressing briefly we confirm
☛ = ↶	Pressing briefly returns
☛ 3s = ↶	Pressing for 3 seconds returns

Each menu can extend to more lines than can be displayed simultaneously on the screen. In this case the rotation of the control gives us access to all options. The device to give a sense of the depth in which each menu extends, displays a vertical bar at the right end of the screen which simulates the segment displayed on the screen in relation to its total length.

During operation, the device momentarily deletes and redisplayes the content of the screen for clarity. Furthermore decreases the brightness of the screen to increase its lifespan and reduce consumption.



From any menu or sub-menu point, the device will return on its own to the home screen and will continue to operate if left for a while without pressing or rotating its knob.



The device settings are stored in a non-volatile memory which is not altered by the power cut-off. The device will return to the function it had immediately before the power loss.

3. Reset

Any change that you make to the device settings can be canceled and the device can be restored to its original state. For this reason, it is recommended to familiarize yourself with the selection of menus and the change of parameters. There is no way to permanently damage the device by modifying settings via the controller and the display. The available recovery modes can be found in the "Settings" submenu.



Figure6

4. Analysis Menu/ Sub Menu

The contents of each menu and sub-menu accessed via the control panel and the display are then analyzed.

Main Menu		
#	Parameter	Explanation
1	Hydraulic scheme	The hydraulic design and parameters related to circulators, the type of collectors and the priority in charging the hot water stores are selected
2	Differential No1	Provides access to parameters related to the operation of the (virtual) differential thermostat No1
3	Differential No2	Provides access to parameters related to the operation of the (virtual) differential thermostat No2
4	Differential No3	Provides access to parameters related to the operation of the (virtual) differential thermostat No3
5	Heating Support	Provides access to parameters related to the engagement of the auxiliary source that warms the domestic hot water.
6	Special functions	Provides access to parameters related to the operation of thermal disinfection, energy measurement, excess heat discharge and wireless transmission (AirLink).
7	Statistics	Statistics such as relay operation time, disinfection time, energy gain etc. are presented
8	Error record	Shows the time and date that occurred and removed the 20 most recent errors as well as their respective codes.
9	Settings	Provides access to parameters related to the format of the screen information, language, time and date etc. Furthermore this sub-menu resets (partially or totally) to factory settings.

Sub-menu: Hydraulic configuration

#	Parameter	Explanation	Adjusting Limits	Pre-set
1	Installation plan	Parameter that determines the form of hydraulic connections in the installation.	1...20	1
2	PWM out max	For circulators with PWM input, it determines the percentage of PWM signal for which the circulator operates at maximum speed.	25%...100%	95%
3	PWM out min	For circulators with PWM input, it determines the percentage of PWM signal for which the circulator operates at minimum speed.	10%...20%	20%
4	PWM out off	For circulators with PWM input, it determines the percentage of PWM signal for which the circulator is switched off.	2%...8%	3%
5	PWM out type	Specifies the type of PWM output signal.	0 = Solar 1=Heating	0: Solar
6	PWM in type	Specifies the type of PWM input signal.	0: NO 1: Grundfos 2: Wilo	0: NO
7	Priority	Determines whether the available stores will be charged in order of priority or simultaneously.	No...Yes	NO
8	Vacuum tube function	If vacuum tube mode is selected, the circulator is sporadically activated to allow the collector water to approach the temperature sensor.	No...Yes	NO
9	Vacuum T. check period	Determines when the circulator will be activated in systems with vacuum tubes.	10min...60min.	10min.
10	Drainback refill time	In drain-back systems, it determines the time that the circulator will be activated at the maximum speed in order for the system to be replenished with the thermal carrier.	0sec...60sec.	5sec.

Sub-menu: Differential No1 to Differential No3

#	Parameter	Explanation	Adjusting Limits	Pre-set
1	ΔT on	Temperature difference to be achieved between two sensors so that the differential controller activates the circulator.	1°C...20°C	10°C

2	ΔT off	Temperature difference between two sensors for which the differential controller will switch off the circulator.	1°C...15°C	8°C
3	Activation delay	The time delay between reaching a temperature difference greater than "ΔT on" until the circulator is activated.	0sec...60sec.	0sec.
4	Anti-freeze	Option to enable freeze protection.	No...Yes	YES
	Anti-freeze temp	Temperature of freezing conditions and activation of the collector circulator.	0°C...5°C	3°C
6	Coll. min temp enable	Select to activate the minimum collector temperature criterion in order to activate the circulator.	No...Yes	YES
7	Collector min temp	For collector temperatures only higher than this, the temperature difference criterion is considered in order to activate the circulator.	10°C...50°C	40°C
8	Store max temp	Temperature limit beyond which the container is considered fully charged and its charge is interrupted by the operation of the collector circulator.	30°C...95°C	65°C
9	Re-cooling enable	When selected, it allows the container with a temperature above the "Store max temp" to discharge on the collectors and piping during the night through the operation of the circulator.	No...Yes	YES
10	Coll. cooling enable	Option to re-operate the circulator even though the container has exceeded the "Store max temp" in order to discharge and protect the collector.	No...Yes	YES
11	Coll max temp	Temperature for which the circulator reoperates in order to protect the collector even though the "Store max temp" has been reached.	95°C...150°C	120°C

12	Pipe protection temp	Collector temperature above which the circulator is stopped in order to protect intermediate piping.	100°C...150°C	150°C
-----------	-----------------------------	--	---------------	--------------

Sub-menu: Heating Support				
#	Parameter	Explanation	Adjusting Limits	Pre-set
1	Support periods	2 time periods within 24 hours are set in which the temperature of the water used is monitored and if it is not satisfactory, the auxiliary source is activated for its heating.	00:00...23:00	00:00- 23:00
2	Temperatures	The starting and ending temperatures of the auxiliary heating source activation shall be determined.	10°C...90°C	Start:35°C End:40°C

Sub-menu: Special functions -> Thermal disinfection				
#	Parameter	Explanation	Adjusting Limits	Pre-set
1	Activation	Enable thermal disinfection mode option.	No...Yes	YES
2	Period	Determines every how many days thermal disinfection will be repeated (active) or controlled (passive).	1d...30d (days)	1 day
3	Duration	Specifies the length of time for which the temperature of the container must be above a temperature limit to consider thermal disinfection successful.	1h...5h (Hours)	1 Hour
4	Temperature	Determines the disinfection temperature.	50°C...80°C	60°C

Sub-menu: Special functions -> Heat gain				
#	Parameter	Explanation	Adjusting Limits	Pre-set
1	Activation	Option to activate the energy gain measurement function.	No...Yes	OXI
2	Return sensor	Determines which of the S2, S3, S4 sensors will be that of the low temperature during measurement.	2...4	4
3	Maximum flow	The constant flow of the thermal carrier in constant speed systems and the maximum in systems with variable speed circulators.	1lt/min...50lt/min.	10lt/min.
4	Heat transfer fluid	Determine the type of thermal carrier.	0: Water 1: Ethylene glycol 2: Propylene glycol	0: Water
5	Concentration (vol)	In thermal carriers that are mixtures and not plain water, the volume ratio of glycol is introduced.	20%...60%	50%

Sub-menu: Special functions -> Heat Dumping				
#	Parameter	Explanation	Adjusting Limits	Pre-set
1	Activation	Option to activate the excess heat discharge function.	No...Yes	OXI
2	Temperature	It determines the collector temperature above which the conditions for activating the excess heat elimination mechanism are considered to be met.	40°C...160°C	110°C
3	Method	Specifies whether the reject mode will only activate R3 output or R1 and R3 simultaneously.	0: On R3 1: R1+R3 on	0: On R3

Sub-menu: Special functions -> Air-Link				
#	Parameter	Explanation	Adjusting Limits	Pre-set
1	Activation	Select to enable the wireless mode.	No...Yes	OXI
2	Address	Specifies the communication address between the device and the smart display.	0...31	31
3	Sensor	Determines the sensor (S1-S4), the temperature of which we wish to be sent and displayed on the smart display.	1...4	2

Sub-menu: Statistics		
#	Parameter	Explanation
1	Heat gain	The energy gain measurement is displayed in MWh (megawatt hours) and kWh (kilowatt hours).
2	Last disinfection	The date and time that became the most recent (active or passive) disinfection is displayed.
3	Runtime	Displays the total running time of the R1-R3 relays.
4	Temperature extremes	Displays the maximum and minimum temperature recorded for each sensor (S1-S4).

Sub-menu: Error record		
#	Parameter	Explanation
1	Incident XX of 20	The event code, its serial number (XX) is displayed along with the time and date that occurred.

Sub-menu: Settings		
#	Parameter	Explanation
1	Language	Specifies the language in which all indications and messages are displayed.
2	Adjust Date- Time	The current time and date are entered.
3	Display type	The type of main operating screen is defined: 1 = Graphics screen 2 = Data display 3 = Switch between graphic and data display
4	Brightness	Specifies the brightness of the display during device operation.
5	Device reset	Provides access to device reset functions e.g. deleting statistics, deleting events, user parameters, etc.
6	Output testing	Enables and disables relay and PWM outputs for diagnostic or control purposes.  From this function, the appliance leaves only by the operator's choice and not automatically after some time has elapsed.

7**Information**

Information about the device version and its manual is presented.

3. General operation



Figure 7

1. Differential thermostat

The basic function of the device is that of the differential thermostat for forced-circulation solar thermal systems. The purpose of the differential thermostat is to remove the thermal energy from the collector and store it in the container with the greatest possible efficiency and maximum safety.

The first step to achieve this is to read the temperatures in a collector and store. If the collector temperature is above a limit called the "Collector min temp", then the numerical difference (collector temperature minus store temperature) is considered. When this is greater than the " ΔT on" limit, then a timer (defined by the "Activation delay") is started after the countdown of which, the device provides a start command in the circulator. The energy stored in the thermal carrier located in the collector, goes to the hot water store and is stored there. The process continues until the numerical difference in collector and store temperatures decreases at least as much as the " ΔT off".

2. Maximum charge - Collector protection

If the temperature of the tank exceeds the maximum temperature limit of the store, the store shall be considered to have been heated to the desired extent and the charge shall be stopped. This can lead to a significant rise in the temperature of the collector. If "Coll. cooling enable" is selected, then, when its temperature exceeds the "Coll. max temp" limit, the device prioritizes protection against overheating of the collector and decides to heat the store beyond the maximum charge temperature. This may continue until the store reaches a temperature of 95C, so it is considered that the absolute charge limit has been reached and the circulator is permanently stopped.

3. Pipe protection

The device has the ability to protect the intermediate pipes and circulator from overheating. The parameter "Pipe protection temp" defines the temperature limit

beyond which the circulator is stopped in order to protect the intermediate hydraulic components.

4. Reverse cooling

Reverse cooling is a useful feature that, if selected, helps protect the system from overheating. It is activated when the collector temperature is at least 5°C lower than that of the store and provided that the store has exceeded the maximum charge temperature.

Reverse cooling results in the elimination of the extra energy of the tank during the night hours, so that the start of the process the next day will find the system in a more favorable condition.

5. Protection from freezing

If the collector temperature is measured and found less than "Anti-freeze temp" and "Anti-Freeze" has been selected at the same time, the device concludes that the conditions for ice creation within the collector and piping are met. To help protect them, it starts the circulator by sending more temperature water into the closed circuit. During this operation, already stored energy of the tank is wasted to protect the system.



Protection against freezing is a supportive method. In cases where a simultaneous power failure occurs, it fails. Furthermore, the measured collector temperature refers to the upper part of the collector that is always warmer and the snow, especially the melting, accumulates at the bottom. For all these reasons it is recommended to fill the closed system with a thermal carrier suitable for resistance against ice formation for the conditions in which the system is intended to operate.

4. Hydraulic Configuration

1. Installation plan

The device offers the option to choose between 20 different hydraulic configurations in each of which 2 or more sensors are involved (S1, S2, S3, S4), one to three relays (R1, R2, R3), up to 3 virtual differential thermostats and one limit thermostat.

Proper matching of the actual hydraulic installation and the design is crucial for the proper operation, performance and safety of the system.

2. PWM output maximum

This parameter is used when the solar field circulator has a PWM speed control input. Determines the percentage of PWM signal for which the circulator will operate at maximum speed.

3. PWM output minimum

This parameter is used when the solar field circulator has a PWM speed control input. Determines the percentage of PWM signal for which the circulator will operate at minimum speed.

4. PWM output off

This parameter is used when the solar field circulator has a PWM speed control input. Determines the percentage of PWM signal for which the circulator stops operating.

5. PWM output type

This parameter is used when the solar field circulator has a PWM speed control input. Specifies the form of the PWM signal. The choice is made between:

0 = PWM Solar circulator function

1= PWM Heating circulator function

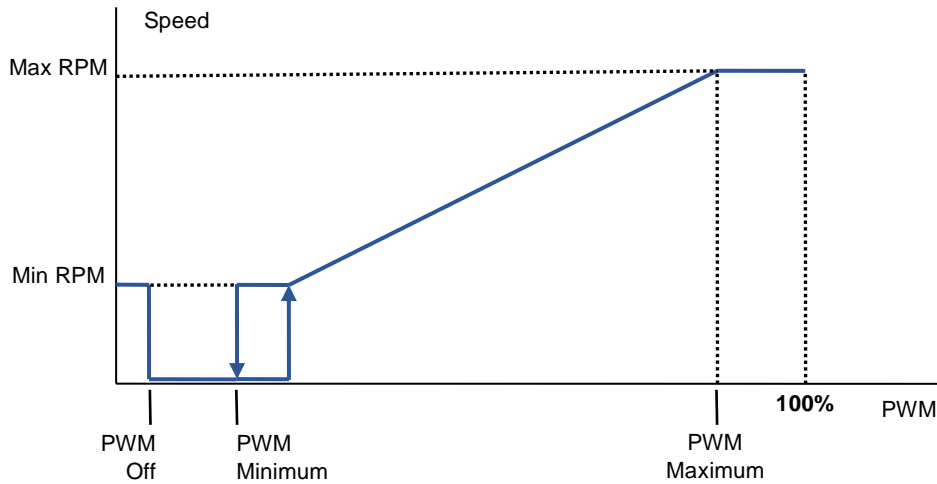

Figure8

6. PWM input type

This parameter is used when the solar field circulator has a status data output (according to PWM standard) to the controller. The available options are:

No = circulator without output status data

Wilo = circulator with an output in accordance with the Wilo standard

Grundfos = circulator with outlet in accordance with the Grundfos standard

7. Priority

In some installations with more than one store, it is possible to charge them either sequentially or simultaneously. When priority is selected, the highest priority store is charged first, then the next one, etc. If a higher thermal tank is discharged when charging a lower priority tank, then the charge of the first one is interrupted and the energy of the solar thermal system is directed to the second.

When the priority feature is not selected, the stores may be charged at the same time, provided that the parameters selected and the measured temperatures allow it.



In systems that allow priority, if only one circulator is activated, it is controlled proportionally and according to the PWM standard. If more than one circulator is activated, their speed control signal operates at maximum speed.

8. Vacuum tube operation

Vacuum tube collectors have the peculiarity that the temperature sensor cannot be placed sufficiently in order to perceive the temperature of the thermal carrier. The vacuum collector function allows hours expected solar activity (7.00-21.00) at regular intervals to activate the collector circulator briefly so that their already hot water reaches the temperature sensor.

9. Vacuum tube repeat period

Determines when the collector circulator will be activated during vacuum collector operation.

10. Refill time

It is used in drain-back systems and refers to the time that the collector's circulator will operate at maximum speed in order to draw a thermal carrier from the runoff vessel and achieve replenishment of the installation.

5. Special Functions

1. Thermal disinfection

The (active) thermal disinfection function can be activated in hydraulic configurations using an auxiliary source to heat the domestic hot water. Its purpose is to contribute to the effort to limit bacteria such as Legionella in water.

When active thermal disinfection is selected, the device monitors the temperature of the water used and when time is elapsed equal to the disinfection period, activates the auxiliary source with thermostatic control at temperatures up to the selected disinfection temperature increased by 10°C. The water temperature rises and thermal disinfection is considered complete when the water is found for longer than the duration of disinfection at a temperature above the disinfection temperature. When disinfection is achieved, the time and date that this happened for the last time are recorded and the "Statistics" screen is presented. If there is a recorded date of previous disinfection, then it is deleted and only the last one is stored.

Thermal disinfection can occur without the use of the auxiliary source (passive thermal disinfection). Similarly, in this case the time of achievement shall be recorded. In addition, the measurement for the period is restarted, contributing to energy savings.

When performing active thermal disinfection or when passive thermal disinfection has elapsed the time of the disinfection period, the flashing thermal disinfection symbol  appears on the display.



For full and guaranteed protection from Legionella, specialized methods, equipment and measurements are required.



Thermal disinfection is an auxiliary method applied to the container only. Additional care should be taken to eliminate bacteria in the water distribution piping.



The sensor, the temperature of which is measured to determine successful disinfection, varies according to the selected hydraulic configuration and refers to the relevant paragraph that is analyzed.

2. Heat gain

The device has the ability to measure the energy gain that is the solar energy collected by the solar collector and directed to the container. The energy gain depends on:

- the temperature of the collector
- the temperature of the return sensor
- the flow of the thermal carrier

- the type of thermal carrier (type of chemical compound and concentration by volume)

The flow sensor is always S1. The return sensor can be selected by the installer and entered in the corresponding menu. The flow is regulated by the electronic control of the circulator and the correct calculation requires that the maximum flow is entered in the corresponding menu. The device enables to select thermal carriers of three kinds:

0 = Water

1 = Ethylene glycol

2 = Propyleneglycol

In cases 1 and 2 the percentage per volume of glycol is required to be introduced into the water.

The measured energy is expressed in kWh and MWh and is reflected in the "Statistics" menu and in the analytical recording screen.

The graphics screen and the detailed recording screen also shows the power at the given time in W or kW.





Figure9

 **Measuring the energy gain is particularly useful and gives a good estimate of the system's ability and regulation. If more accurate recording is required, it is recommended to install a separate calorimeter.**

3. Heat rejection

Excess heat is the heat that cannot be stored in a container at the time. If this action is left to the collector, it is possible to cause problems such as boiling, vaporizing and breaking the pipes.

When the heat rejection function is selected, the symbol appears on the  descending tubing from the collector. When the function is activated, the symbol is replaced by the .

The device has the ability to detect and manage the excess heat of the collector. In order to achieve this, the corresponding feature must be activated and the collector temperature above which the energy balance of the collector-container is considered to have been overturned and the collector can now generate more energy than can be stored in the container. Then the R3 output of the controller is activated, which can be led to an alarm indicator or activate an auxiliary energy removal device from the collector or the container e.g. air water heat exchanger, cold water inlet valve, outlet valve in the drain of the excessively heated water of the water tank etc.

The function of disposing of excess heat other than R3 may, if necessary, simultaneously activate the collector circulator via R1. The options of the method are two:

0= Only R3 is activated

1= R3 and R1 are activated at maximum speed.

4. Wireless - AirLink

The device offers the ability to wirelessly transmit and display the temperature of any sensor on a corresponding wireless display via the AirLink protocol. The AirLink specific transmission module should be installed in the corresponding slot inside the device under the display.

For the correct transmission, the settings to be made from the corresponding menu refer to the sensor whose temperature we want to see and the communication address between the device and the wireless display.

Wireless transmission is a very useful feature that allows direct monitoring of the temperature of the water use and which in many facilities e.g. hotels are crucial.

The communication between device and monitor is made at a frequency of 433.92MHz which allows for satisfactory penetration into the building elements and long range.

6. Heating support

Heating support is a very useful feature that activates the auxiliary source to heat the store in case the solar radiation is not sufficient. If the temperature of the store is measured below the "Start" temperature, the auxiliary source is activated and remains active until the temperature exceeds the "Stop" limit.

Heating support is beneficial because it ensures that hot water is prepared in the most appropriate way. For this reason, the power-on and power-off limits must be kept low,

always having the meaning of the last backup before water is declared unsuitable for use due to low temperature.



The purpose of heating support is to always provide hot water to the installation, taking advantage of the available sources. For this reason, it can happen that the auxiliary source and the collector circulator are activated simultaneously. This is perfectly normal because the primary source that is the sun is unable to heat the water and therefore decides that in order to maintain the minimum temperature limit required, the auxiliary source must be involved.

However, there are cases when the auxiliary source is only available at certain times, e.g. in the evening or in the hours when there is expected to be solar activity. The device allows two time periods per 24 hours to be selected, in which the water temperature is monitored and the auxiliary source is involved when necessary. If we want the auxiliary source to be able to be engaged throughout the 24-hour period, it is necessary to define one of the two available periods from 00:00 to 23:59.

7. Detection and recording of errors

The device incorporates a series of sophisticated features related to the detection, troubleshooting and recording of errors that may occur during its operation. Their purpose is to protect the installation and inform the technician to lead to their short resolution.

The errors detected are:

1. S1 sensor error
2. S2 sensor error
3. S3 sensor error (if involved in the selected hydraulic installation)
4. S4 sensor error (if involved in the selected hydraulic installation)
5. Non-recoverable memory error
6. Recoverable memory error
7. Circulator error (if a circulator with PWM output is used)

1-4 Sensor errors



Faults involving damaged or short-circuited sensors are detected. It is not possible to detect errors involving incorrect type sensors or sensors that show slightly altered temperature.

7. Circulator error

Fault is detected and not the cause of e.g. overheating, hydraulic part stall, flow mismatches, etc.

5-6 memory errors are related to the alteration of operating data stored in the device and may result from voltage fluctuations and generally poor current quality. They usually lead the device to incorrect operation and can have significant and devastating consequences for the installation. The device is able to repair such errors on its own (AMR system) and continue to operate smoothly. In fact, the detection of a high frequency of such errors is a sign of poor quality current or poor electrical installation.

However, there is a possibility that the memory corruption has occurred to such an extent that automatic repair by the device is impossible. In this case, the installer must reset all its settings, which results in the settings being lost and needs to be reset.

Each error when it occurs and is detected by the device is logged in the event file (in total it can record 20 events along with the time and date that occurred). Position 20th stores the most recent event and the oldest one at 1st. If the number of events exceeds 20, the oldest of them is deleted. So the installer has a complete series of events that help him deal with the situation. Events recorded in the log are considered both those of error creation and those of their repair. So, for example, if a sensor is disconnected and then

reconnected, the event log will record, in addition to the type of problem, the time it occurred and the time it was fixed.

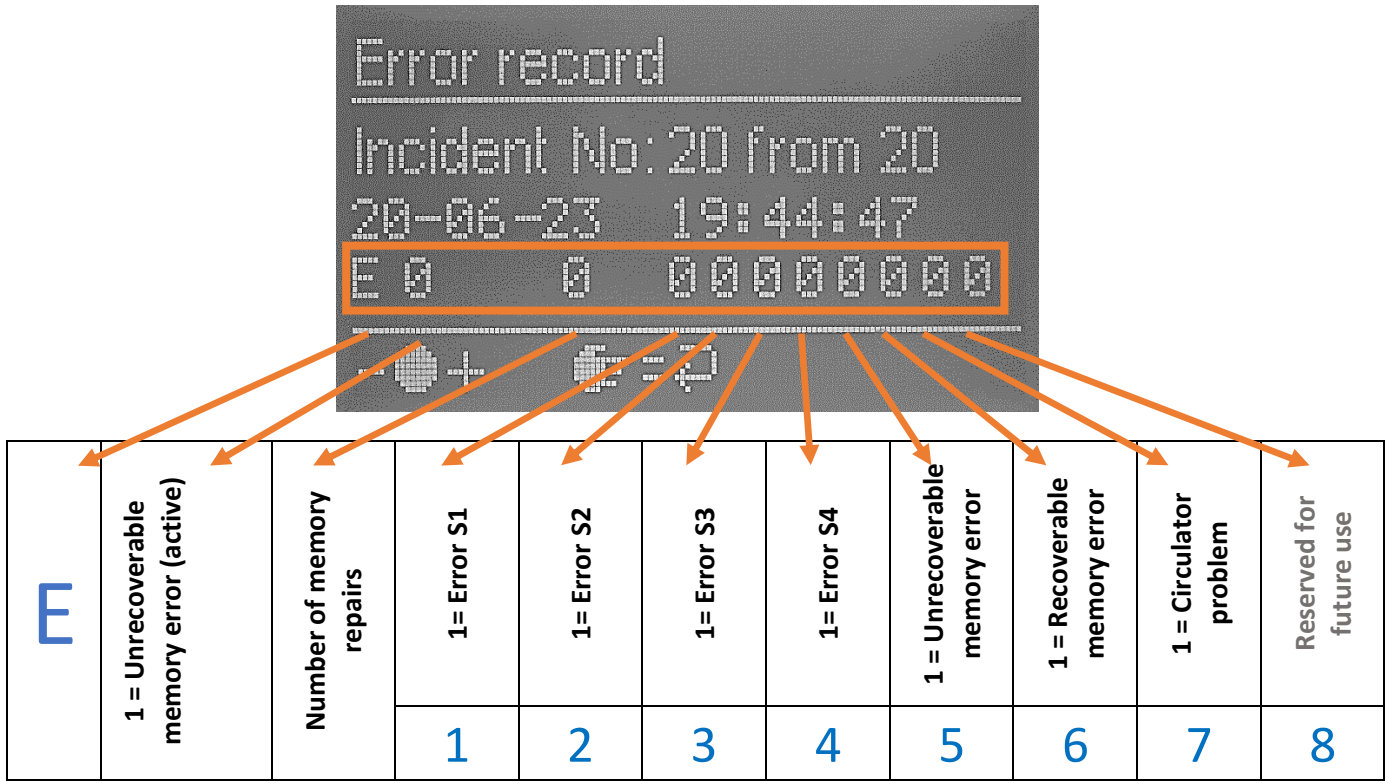

Figure10

In the event of a critical error (all errors except 6=Recoverable memory error), the device shuts down its normal operation and switches to a security state, leading its outputs to an appropriate state with the main purpose of protecting the system. For example, the collector's circulator is driven in continuous operation to prevent overheating and vaporization in the collector. By the same logic the outputs that activate auxiliary sources are put into inactivity.

In the event of a critical error, the RotorFlex rotary control is illuminated by flashing bright red light. In order to have a direct supervision of the errors that are active at this time, it is enough to press the RotorFlex control, which leads directly to the error summary screen before the main setup menu. If the installer wants to be more informed about the time or sequence of occurrence, it has the opportunity to visit the "Error record" section.

PS301k0 sensor	
Temperature-ohmic resistance mapping table	
Temperature	Resistance
0 °C	1000 Ohms
10 °C	1040 Ohms
20 °C	1080 Ohms
30 °C	1120 Ohms
40 °C	1160 Ohms
50 °C	1200 Ohms
60 °C	1230 Ohms
70 °C	1270 Ohms
80 °C	1310 Ohms
90 °C	1350 Ohms
100 °C	1390 Ohms
110 °C	1420 Ohms
120 °C	1460 Ohms
130 °C	1500 Ohms

8. Installation plans

The 20 hydraulic configurations of a solar power plant are then presented. In each configuration there is a table that gives a lot of information about the operation of the installation and its basic structural elements such as thermal storage tanks, collectors, sensors etc.

Example 1

Sensors	Control unit	Relationship	Exit
S1	Differential No1	➔	R1
S2			
S3	Heating Support	➔	R2
Operation			
Thermal disinfection		Available (active via R2)	
Heat rejection		Available (via R3)	

In this example, the S1 and S2 sensors are connected to the virtual differential thermostat No1 which directly controls (column "relationship") on relay R1. S3 is connected to the heating support unit that directly activates relay R2. This table also specifies the availability of other functions such as thermal disinfection and disposal of excess heat.

Example 2

Sensors	Control unit	Relationship	Exit
S1	Differential No1	⊗	R1
S2			
S1	Differential No2		R2
S3			
Operation			
Thermal disinfection		Available (passive)	
Heat rejection		Available (via R3)	

In this example, the S1 and S2 sensors are connected to the virtual differential thermostat No1 and S1 and S3 with the virtual differential thermostat No2. The differential function, if no priority is set, is independent. But if priority is set, then differential No2 expects differential No1 to be completed and then commands R2 (relationship column).

This example also specifies the availability of other functions, such as thermal disinfection and disposal of excess heat.

Plan No1

Sensors	Control unit	Relationship	Exit
S1	Differential No1	➔	R1
S2			
Operation			
Thermal disinfection		Available (passive)	
Heat rejection		Available (via R3)	

Simple differential thermostat function for charging the store via the collector circulator activated by relay R1.

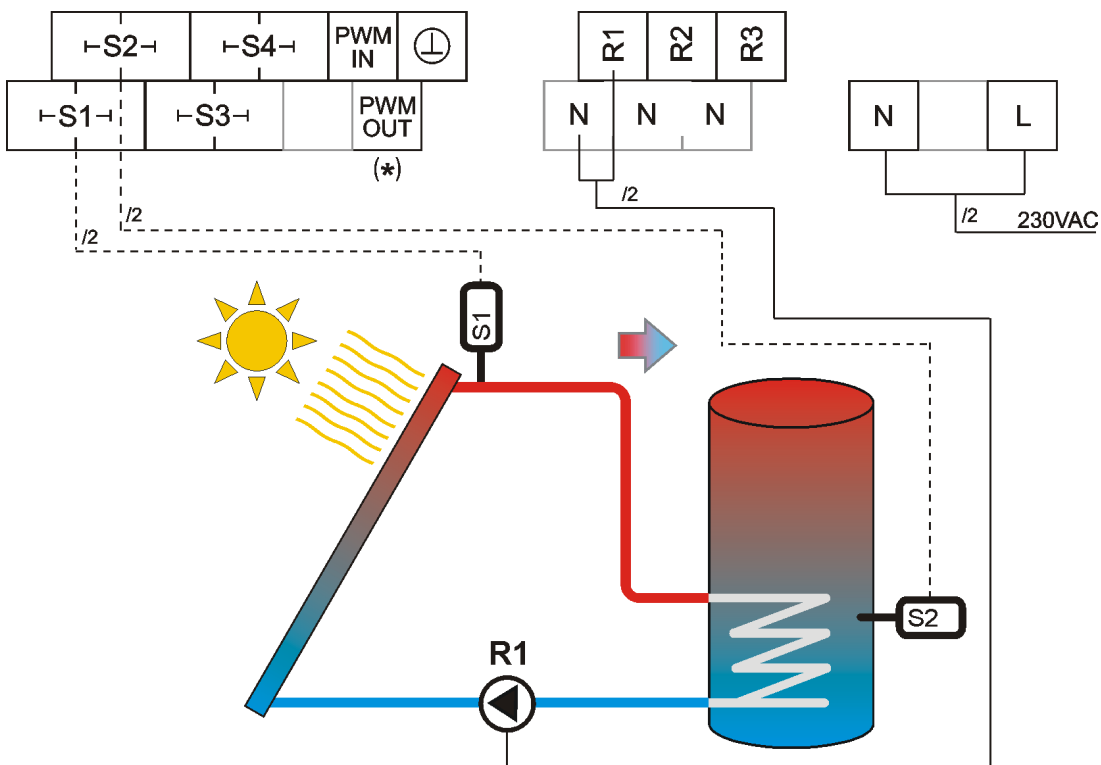

(*) the connections of the PWM cable of the circulator are described in the section "Electrical connections".

Plan No2

Sensors	Control unit	Relationship	Exit
S1	Differential No1	➔	R1
S2			
S3	Differential No2	➔	R2
S4			
Operation			
Thermal disinfection		Available (passive)	
Heat rejection		Available (via R3)	

Differential thermostat function for charging the first (left) store via the collector circulator activated by relay R1.

The second store is charged by differential control from the first via the circulator R2.

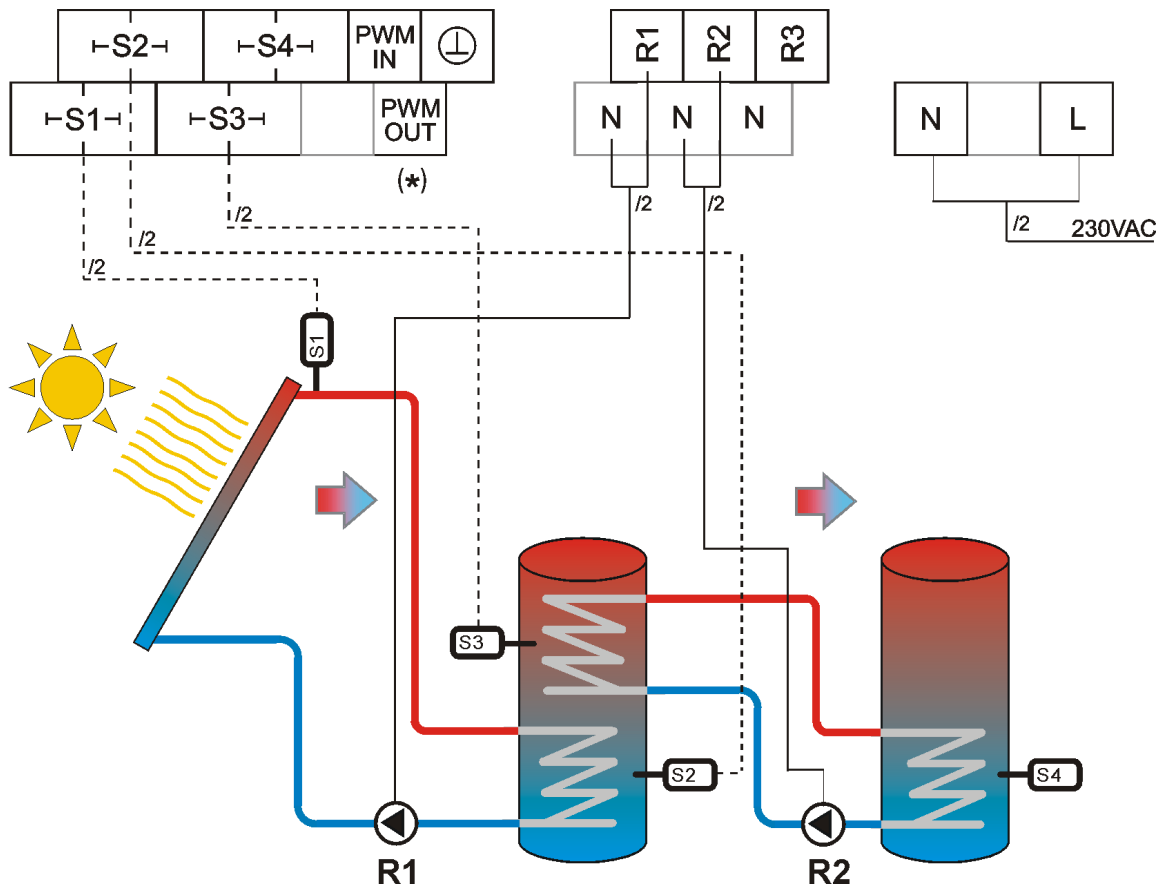

(*) the connections of the PWM cable of the circulator are described in the section "Electrical connections".

Plan No3

Sensors	Control unit	Relationship	Exit
S1	Differential No1	➔	R1
S2			
S3	Heating Support	➔	R2
Operation			
Thermal disinfection		Available (active via R2)	
Heat rejection		Available (via R3)	

Differential thermostat function for charging the storer via the collector circulator activated by relay R1. If the solar activity is not enough, the store is charged by thermal support from an external source e.g., boiler, resistance, heat pump activated by relay R2 with simple thermostatic control.

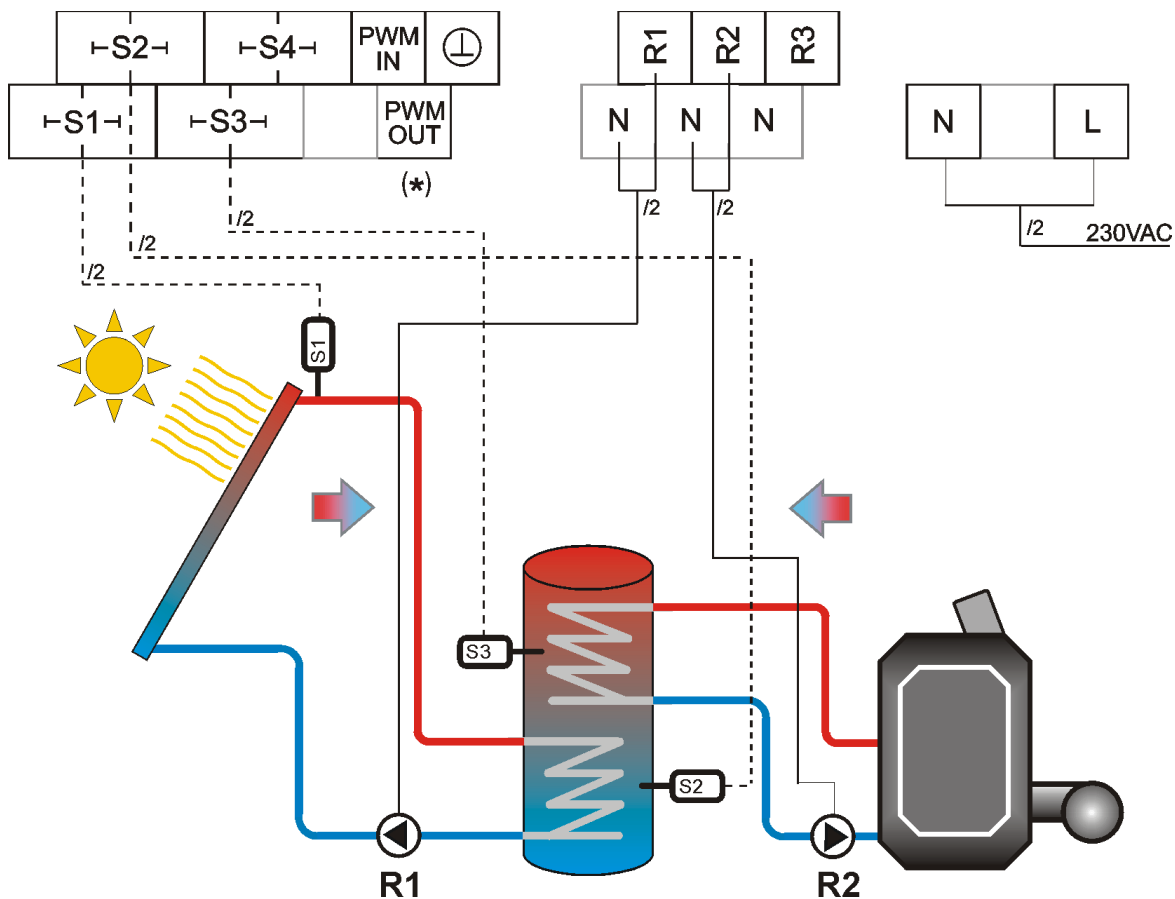

(*) the connections of the PWM cable of the circulator are described in the section "Electrical connections".

Plan No4

Sensors	Control unit	Relationship	Exit
S1	Differential No1		R1
S2			
S1	Differential No2		R2
S3			
Operation			
Thermal disinfection		Available (passive)	
Heat rejection		Available (via R3)	

In this plan priority is the rapid heating of the upper part of the store from which the consumption is made. When the upper part has been sufficiently heated, the energy is directed to the lower part to complete its charge.

It includes a differential thermostat function to charge the upper part of the store through the collector circulator activated by relay R1.

The bottom of the tank is charged by differential control via the R1 circulator and the activated valve from relay R2.

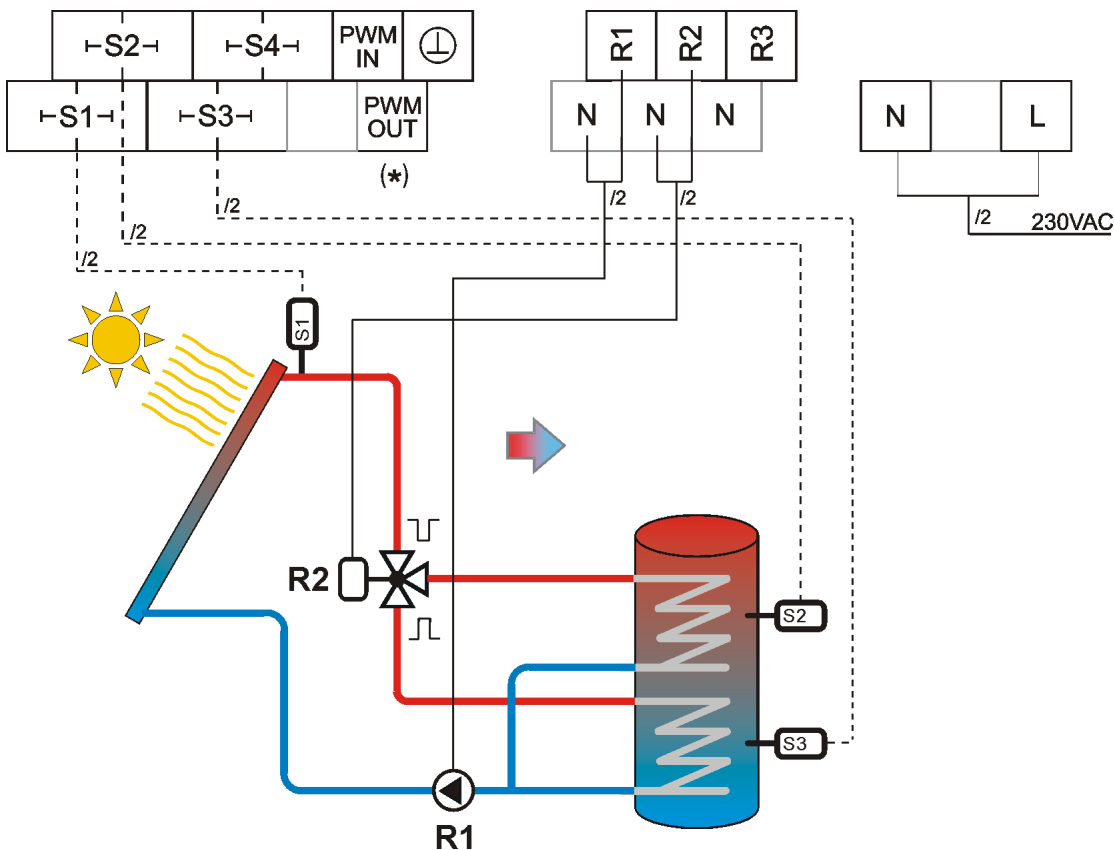

(*) the connections of the PWM cable of the circulator are described in the section "Electrical connections".

Plan No. 5

Sensors	Control unit	Relationship	Exit
S1	Differential No1		R1
S2			
S1	Differential No2		R2
S3			
Operation			
Thermal disinfection		Available (passive)	
Heat rejection		Available (via R3)	

In this design priority is the quick heating of the left-hand store. When it has been sufficiently heated, the energy is directed to the right-hand store.

It includes a differential thermostat function to charge the left-hand store through the collector circulator activated by relay R1.

The right-hand store is charged by differential control via the R1 circulator and the activated valve from relay R2.

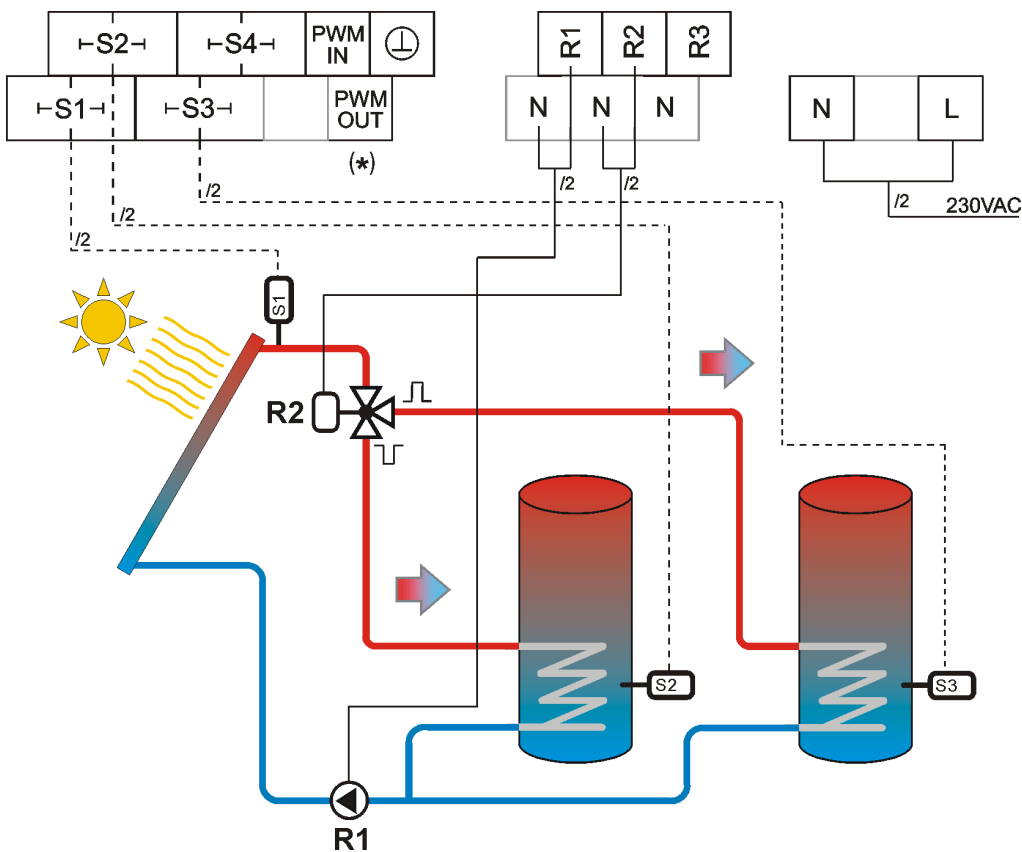

(*) the connections of the PWM cable of the circulator are described in the section "Electrical connections".

Plan No6

Sensors	Control unit	Relationship	Exit
S1	Differential No1		R1
S2			
S1	Differential No2		R2
S3			
Operation			
Thermal disinfection		Available (passive)	
Heat rejection		Available (via R3)	

This design can work with or without priority charging in the stores. If priority is selected, then the left store is charged first and then the right, that is, the sequential charge is followed. If priority is not selected, then the stores are charged independently if the appropriate temperature conditions are met.

It includes a differential thermostat function to charge the left-hand store through the collector circulator activated by relay R1.

The right-hand store is also charged by differential control via the R2 circulator.

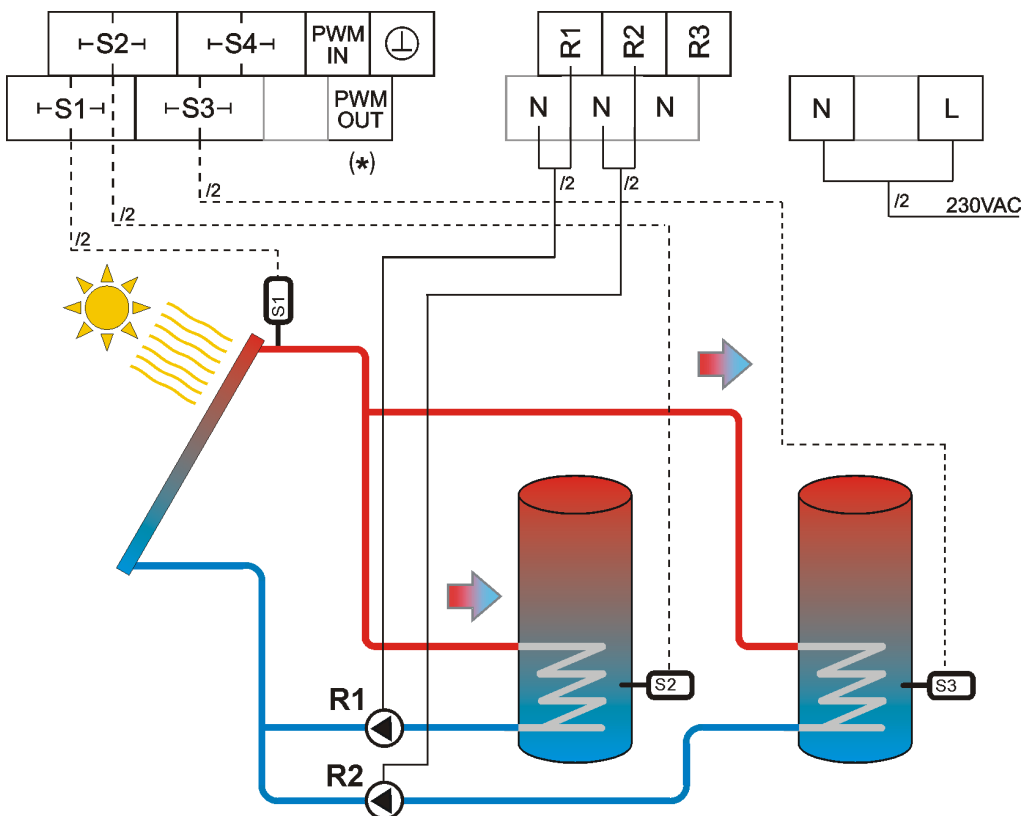

(*) the connections of the PWM cable of the circulator are described in the section "Electrical connections".

Plan No7

Sensors	Control unit	Relationship	Exit
S1	Differential No1	➔	R1
S2			
S3	Differential No2	➔	R2
S2			
Operation			
Thermal disinfection		Available (passive)	
Heat rejection		Available (via R3)	

This design is applied in cases of two collector fields with different orientation. Its function is based on the charging of the store from any collector field this is possible or even from both at the same time.

It includes two differential thermostats to charge the tank via the circulators activated by relays R1 and R2.

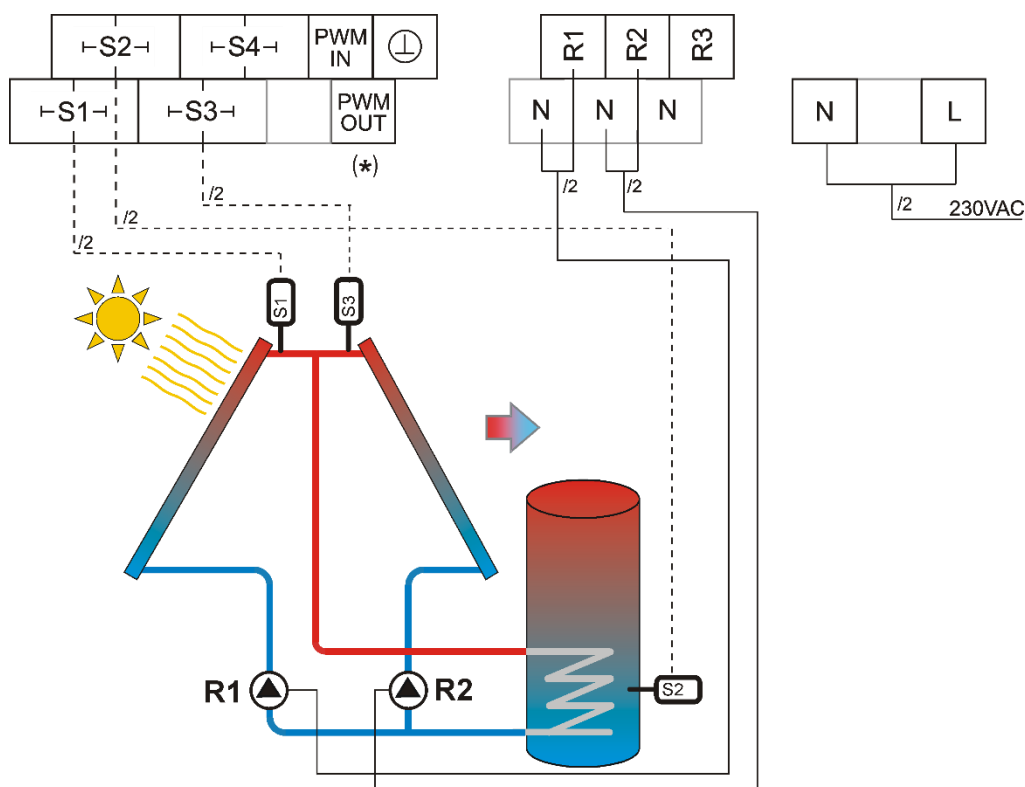

(*) the connections of the PWM cable of the circulator are described in the section "Electrical connections".

Plan No8

Sensors	Control unit	Relationship	Exit
S1	Differential No1	➔	R1
S2			
S4	Differential No2	➔	R2
S3			
Operation			
Thermal disinfection		Available (passive)	
Heat rejection		Available (via R3)	

In this design, a solar thermal system coexist with a source of support of non-stable potential e.g. wood boiler, hydrothermal fireplace, etc.. Its function is based on the charging of the store by the collector with differential control and by the auxiliary source also with differential control.

It includes two differential thermostats to charge the tank via the circulators activated by relays R1 and R2.

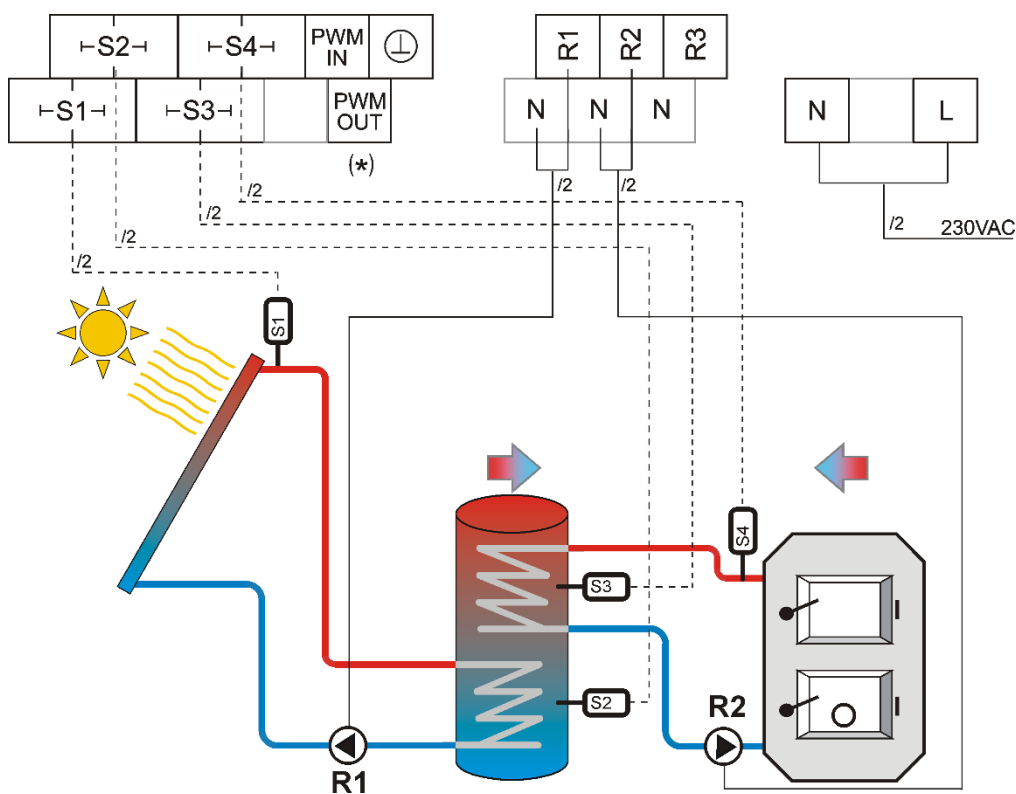

(*) the connections of the PWM cable of the circulator are described in the section "Electrical connections".

Plan No9

Sensors	Control unit	Relationship	Exit
S1	Differential No1		R1
S2			
S1	Differential No2		R2
S3			
S1	Differential No3		R3
S4			
Operation			
Thermal disinfection		Available (passive)	
Heat rejection		Not available	

This plan can work with or without priority charging in the stores. If priority is selected, then the left store is charged first, then the middle and then the right, followed by the sequential charge. If priority is not selected, then the stores are charged independently if the appropriate temperature conditions are met.

It includes a three differential thermostat function to charge the store through the collector circulators activated by relays R1, R2 and R3.

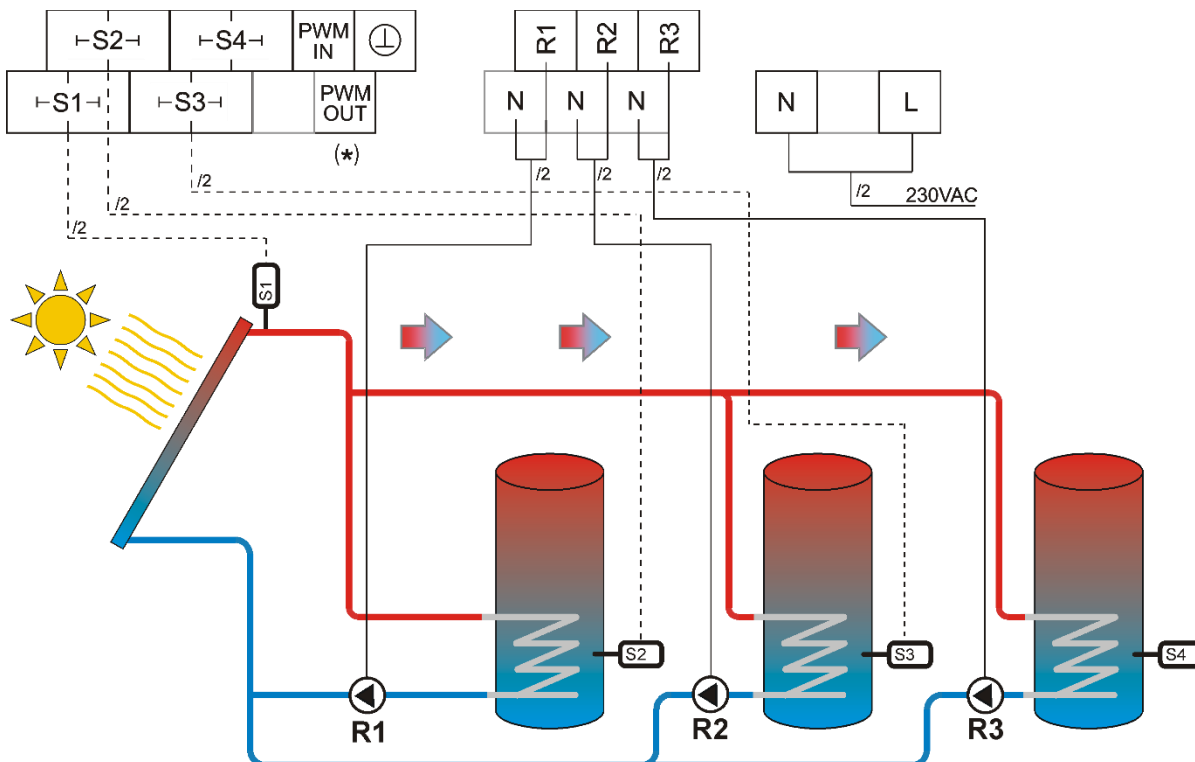

(*) the connections of the PWM cable of the circulator are described in the section "Electrical connections".

Plan No10

Sensors	Control unit	Relationship	Exit
S1	Differential No1	➔	R1
S2			
S3	Differential No2	➔	R2
S2			
S4	Heating Support	➔	R3
Operation			
Thermal disinfection		Available (active via R3)	
Heat rejection		Not available	

This design is applied in cases of two collector fields with different orientation. Its function is based on the charging of the store from any collector field this is possible or even from both at the same time.

It includes two differential thermostats to charge the tank via the circulators activated by relays R1 and R2.

An auxiliary source activated for thermal support is included via relay R3.

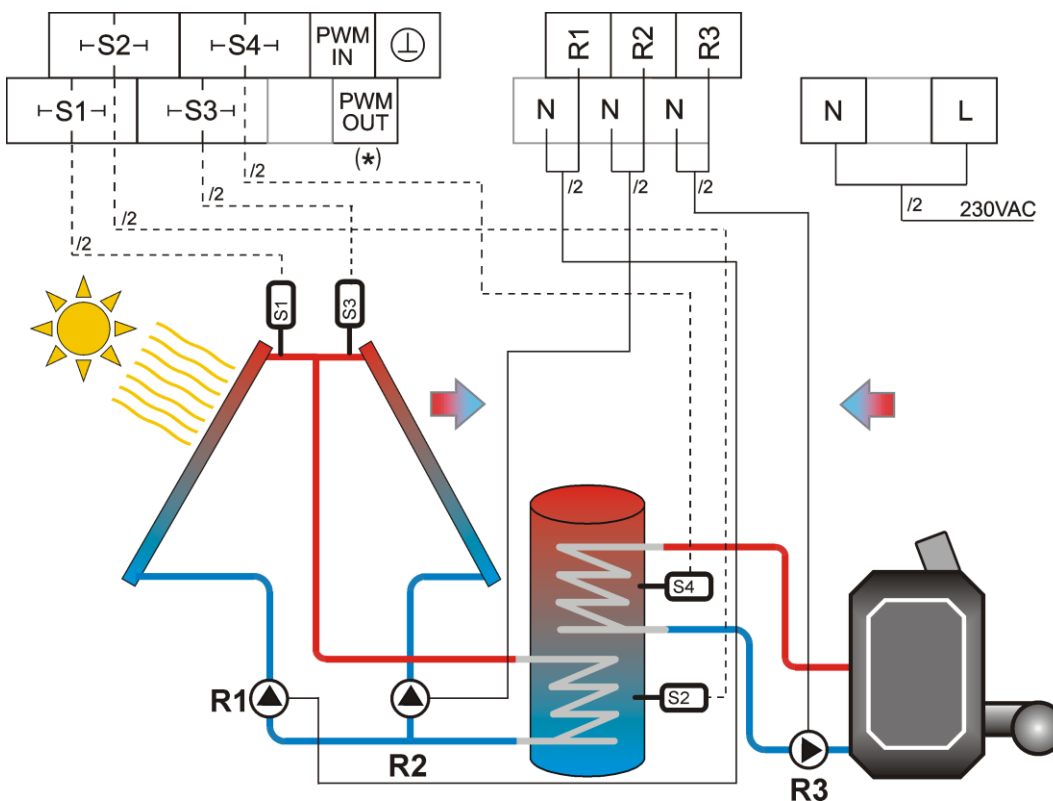

(*) the connections of the PWM cable of the circulator are described in the section "Electrical connections".

Plan No11

Sensors	Control unit	Relationship	Exit
S1	Differential No1	➔	R1
S2			
S3	Differential No2	➔	R2
S2			
S2	Heating Support	➔	R3
Operation			
Thermal disinfection		Available (active via R3)	
Heat rejection		Not available	

This plan is applied in cases of two collector fields with different orientation. Its function is based on the charging of the store from any collector field this is possible or even from both at the same time.

It includes two differential thermostats to charge the tank via the circulators activated by relays R1 and R2.

An auxiliary source activated for thermal support is included via relay R3.

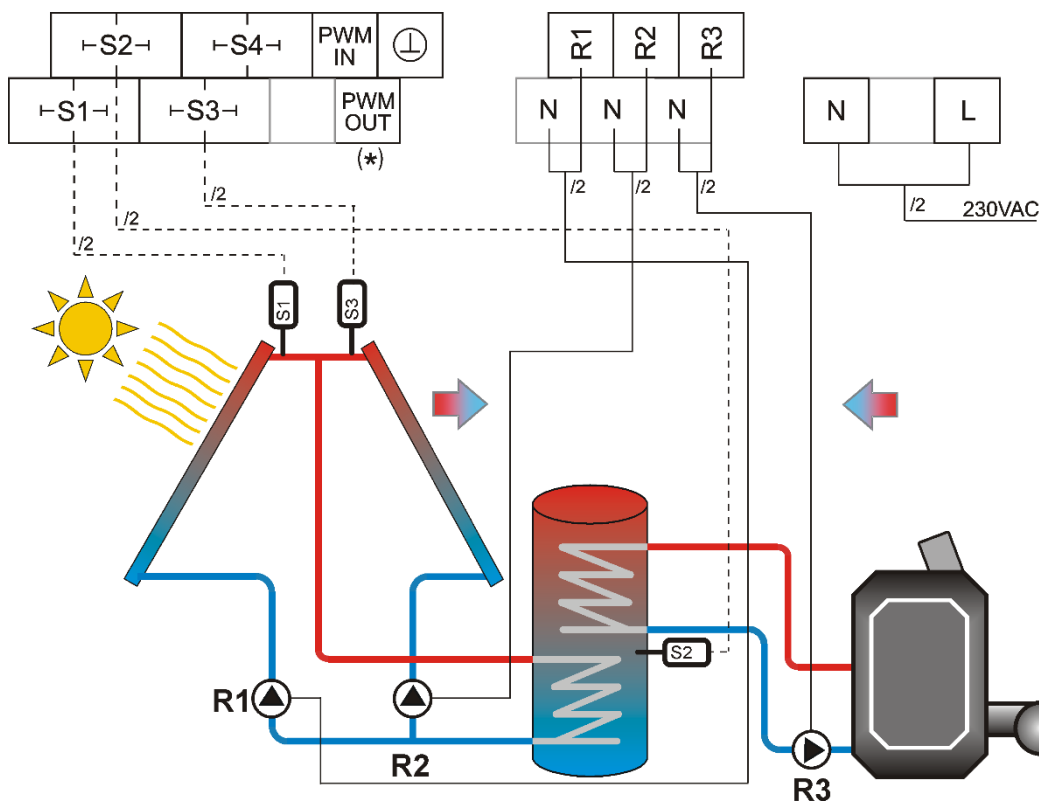

(*) the connections of the PWM cable of the circulator are described in the section "Electrical connections".

Plan No12

Sensors	Control unit	Relationship	Exit
S1	Differential No1	➔	R1
S2			
S2	Heating Support	➔	R2
Operation			
Thermal disinfection		Available (active via R2)	
Heat rejection		Available (via R3)	

The design includes simple solar thermal system and auxiliary source (boiler, resistance, heat pump) with a sensor in the stores.

It is based on the differential thermostat function for charging the store via the collector circulator activated by relay R1.

If the solar activity is not enough, the store is charged by thermal assistance from an external source e.g., boiler, resistance, heat pump activated by relay R2

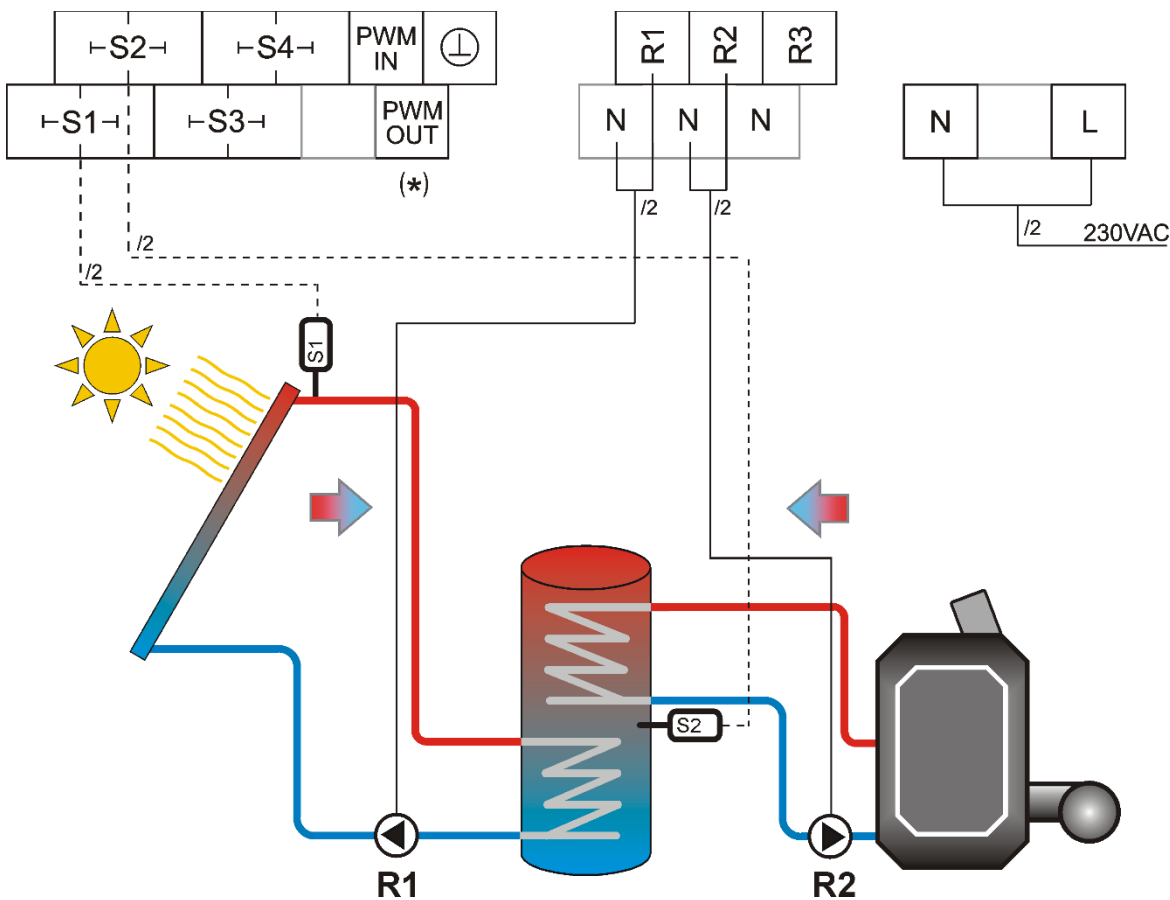

(*) the connections of the PWM cable of the circulator are described in the section "Electrical connections".

Plan No13

Sensors	Control unit	Relationship	Exit
S1	Differential No1		R1
S2			
S1	Differential No2		R2
S4			
S3	Heating Support		R3
Operation			
Thermal disinfection		Available (active via R3)	
Heat rejection		Not available	

This plan can work with or without priority charging in the stores. If priority is selected, then the right store is charged first and then the left, that is, the sequential charge is followed. If priority is not selected, then the stores are charged independently if the appropriate temperature conditions are met.

It includes a differential thermostat function to charge the right-hand store through the collector circulator activated by relay R1.

The right-hand store is also charged by differential control via the R2 circulator.

It is also possible to integrate an auxiliary source via relay R3.

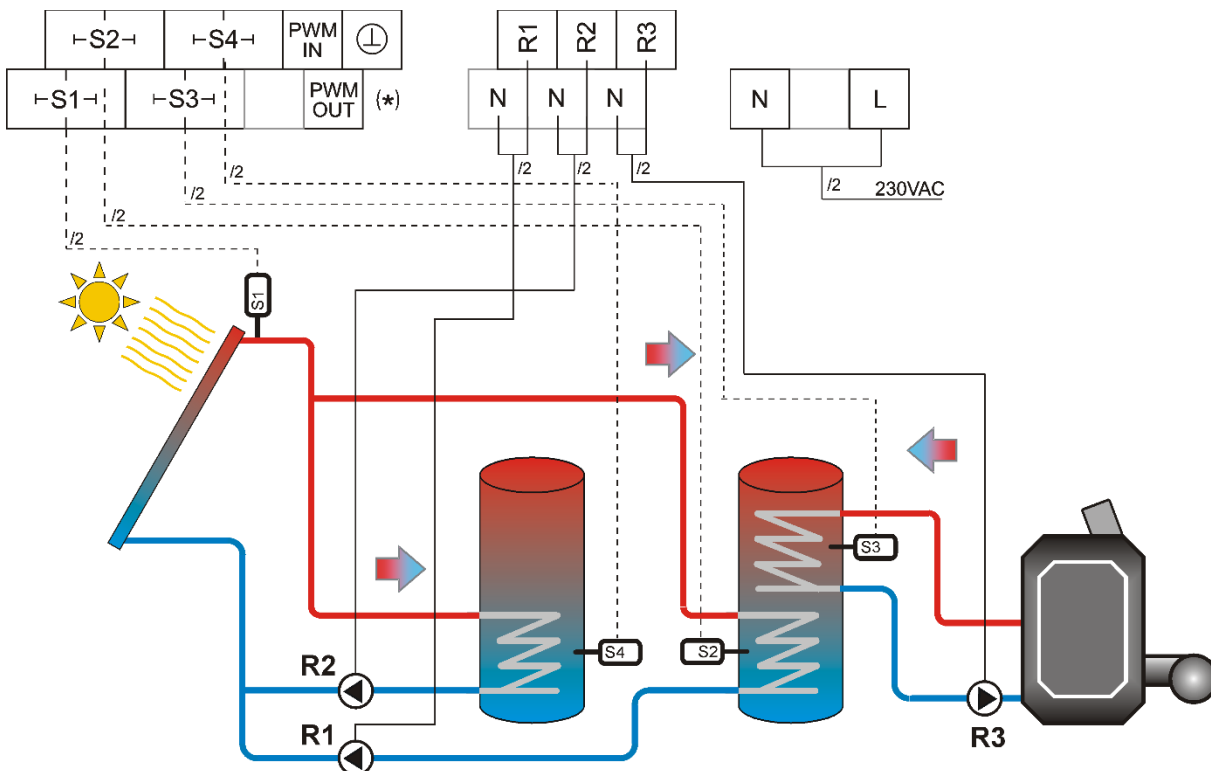

(*) the connections of the PWM cable of the circulator are described in the section "Electrical connections".

Plan No14

Sensors	Control unit	Relationship	Exit
S1	Differential No1	➔	R1
S2			
S4	Differential No2	➔	R2
S3			
Operation			
Thermal disinfection		Available (passive)	
Heat rejection		Available (via R3)	

In this plan it is applied in cases of solar thermal system in combination with boiler and direct driving of consumption from the boiler.

Its function is based on the charge of the store by the collector with differential control. The heating of the space is done by the boiler or through again differential control with simultaneous assistance from the store.

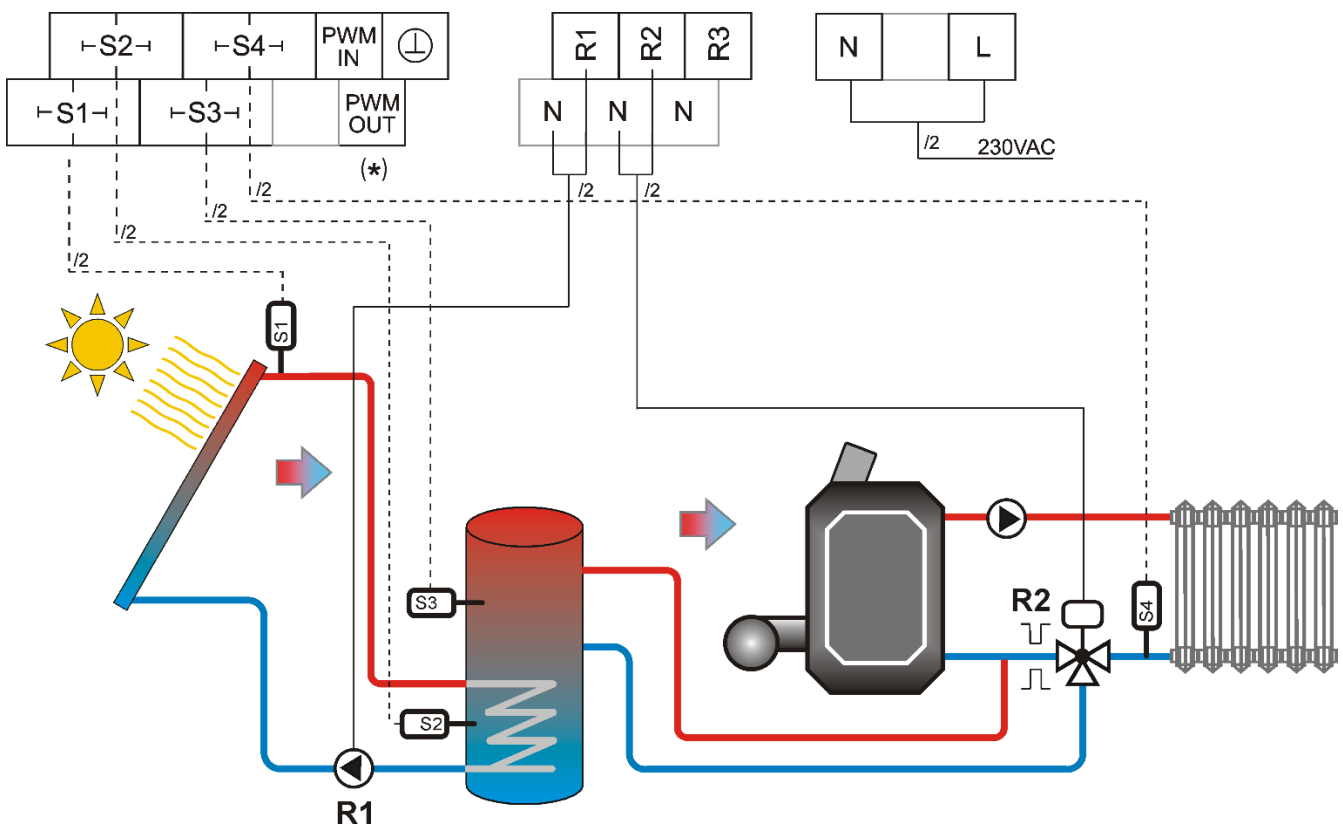

(*) the connections of the PWM cable of the circulator are described in the section "Electrical connections".

Plan No15

Sensors	Control unit	Relationship	Exit
S1	Differential No1	➔	R1
S2			
Operation			
Thermal disinfection		Not applicable	
Heat rejection		Available (via R3)	

This design is based on the simple differential thermostat function to directly charge the pool via the collector circulator activated by relay R1.

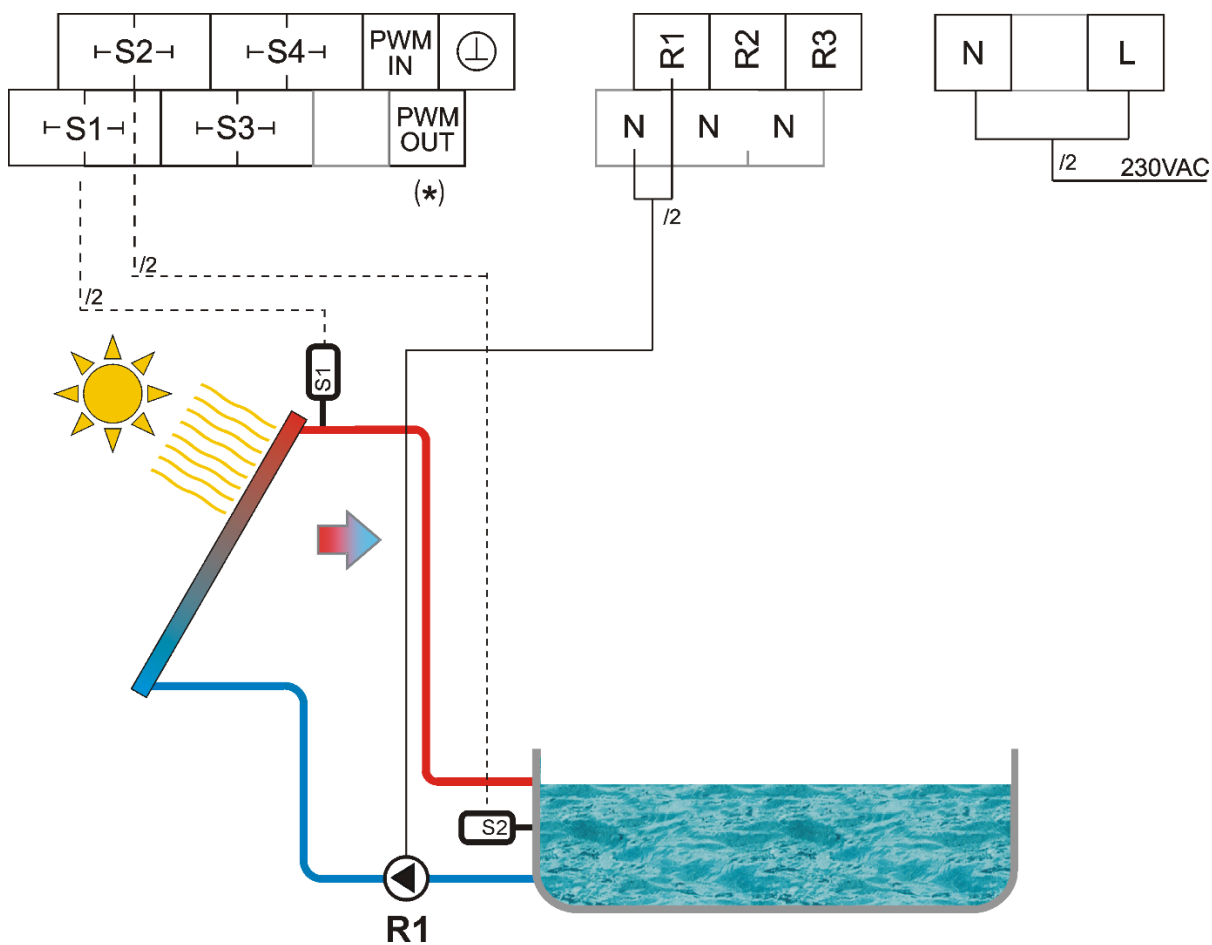

(*) the connections of the PWM cable of the circulator are described in the section "Electrical connections".

Plan No16

Sensors	Control unit	Relationship	Exit
S1	Differential No1	➔	R1
S2			
S3	Differential No2	➔	R2
S2			
Operation			
Thermal disinfection		Not applicable	
Heat rejection		Available (via R3)	

This design is based on the pool charging function through heat exchanger and double differential control.

The determination of suitable heat transfer conditions to the pool is initiated by the differential thermostat No1 that activates relay R1.

The No2 differential then takes over the transfer from the heat exchanger to the pool water, activating relay R2.

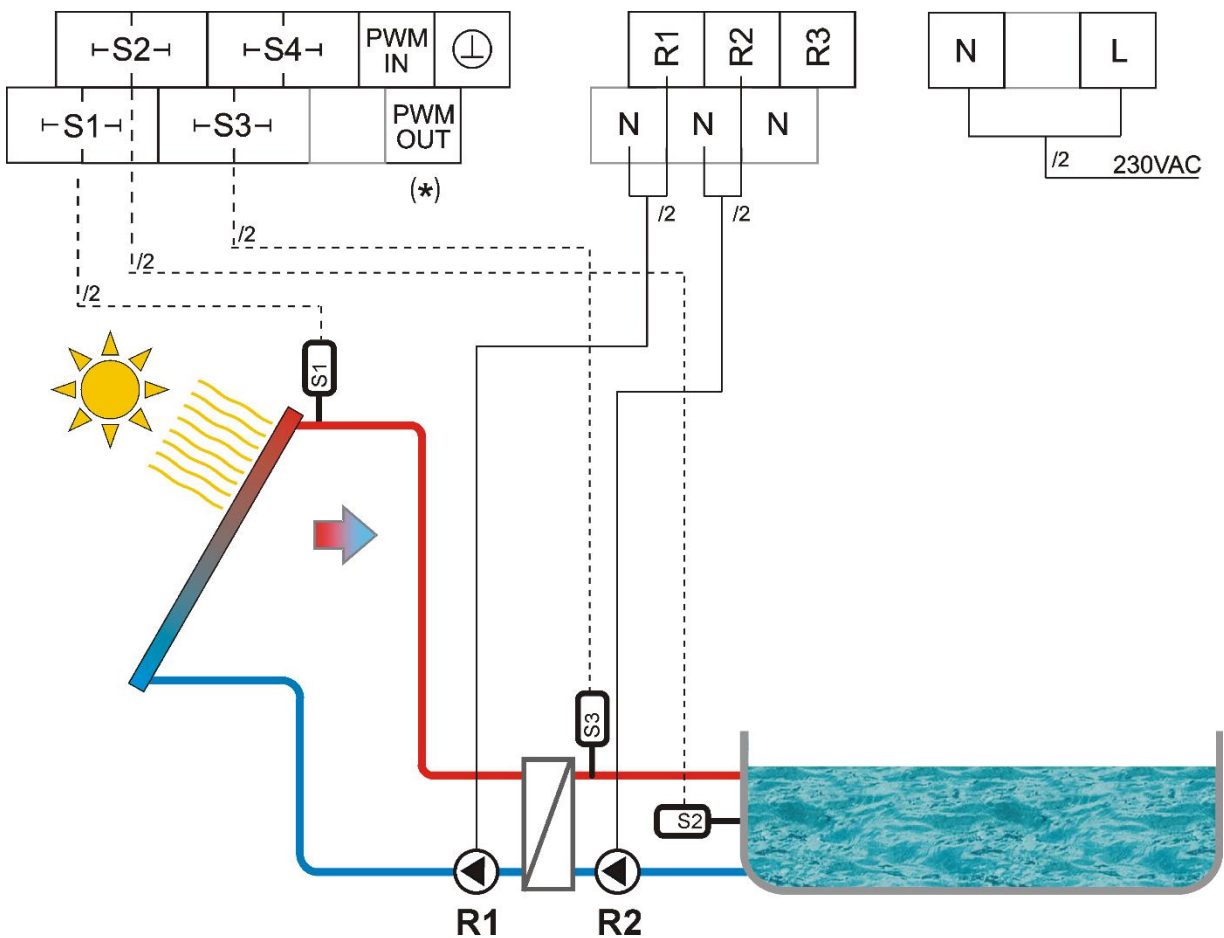

(*) the connections of the PWM cable of the circulator are described in the section "Electrical connections".

Plan No17

Sensors	Control unit	Relationship	Exit
S1	Differential No1	➔	R1
S2			
S3	Heating Support	➔	R3
S3	Differential No2	➔	R2
S4			
Operation			
Thermal disinfection		Available (active via R3)	
Heat rejection		Not available	

This design provides a store charging function, boiler assistance function and complete recirculation control of hot water use.

The charge of the tank is performed by differential control from differential No1 which activates relay R1.

Boiler assistance activates relay R3 when no heating of the use water has been achieved.

The recirculation of the use water is controlled by a limit thermostat and simultaneous differential control by differential number 3 which activates relay R2.

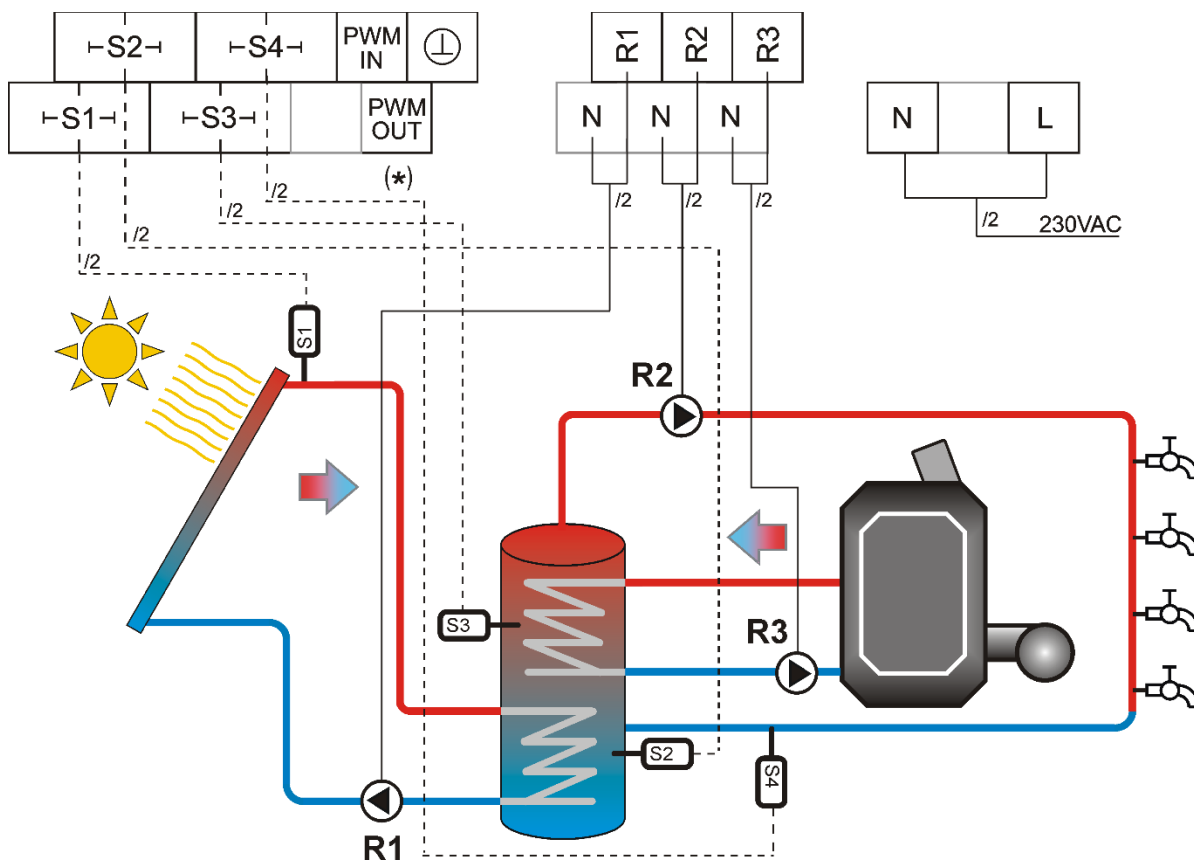

(*) the connections of the PWM cable of the circulator are described in the section "Electrical connections".

Plan No18

Sensors	Control unit	Relationship	Exit
S1	Differential No1	➔	R1
S2			
S3	Heating Support	➔	R3
S3	Differential No2	➔	R2
S4			
Operation			
Thermal disinfection		Available (active via R3)	
Heat rejection		Not available	

In this plan it is applied in cases of solar thermal system in combination with a boiler for charging the water of the container for heating spaces.

The device undertakes to supply energy into the space according to the load of the installation. The heating of the space is done through differential control and provided that the store is sufficiently heated.

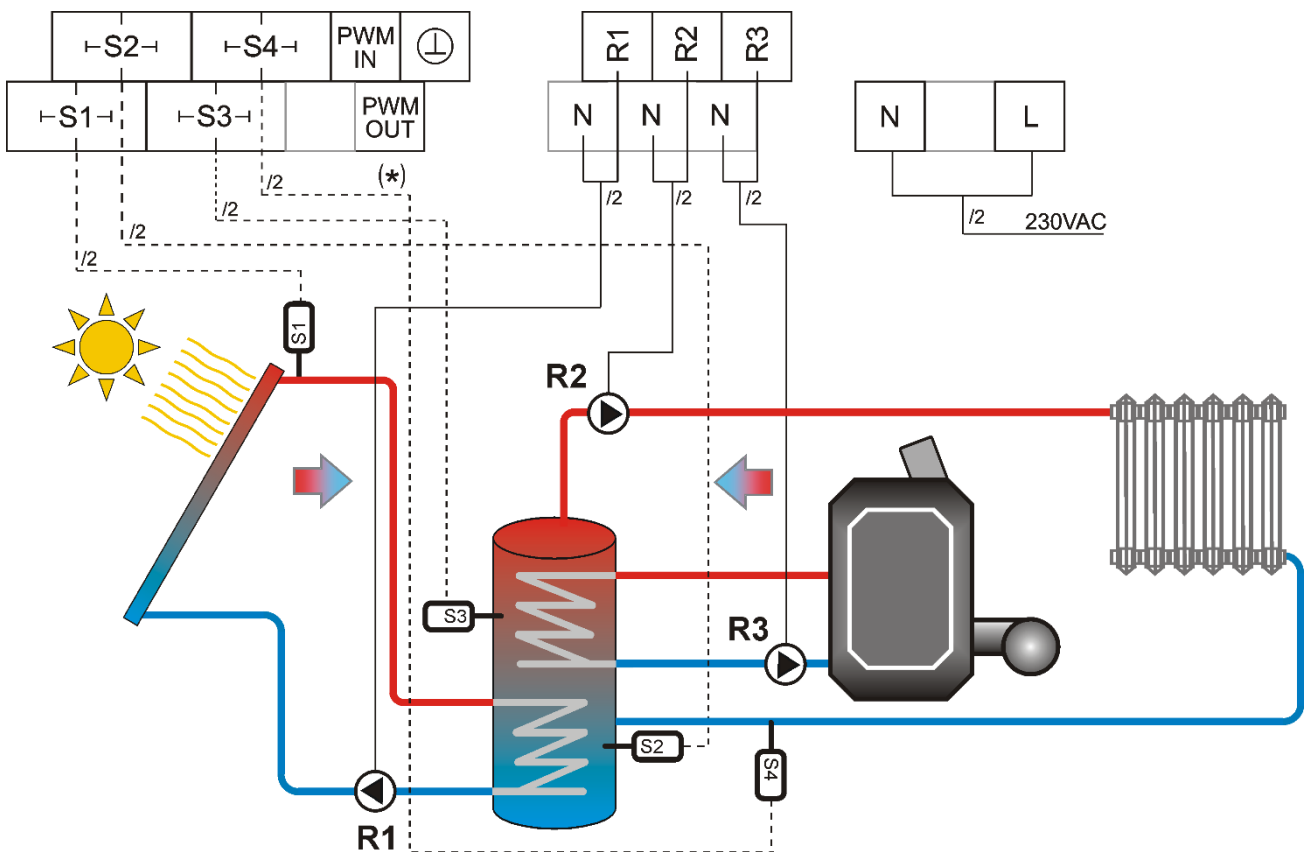

(*) the connections of the PWM cable of the circulator are described in the section "Electrical connections".

Plan No19

Sensors	Control unit	Relationship	Exit
S1	Differential No1	➔	R1
S2			
S3	Heating Support	➔	R3
S4	Differential No2	➔	R2
S2			
Operation			
Thermal disinfection		Available (active via R3)	
Heat rejection		Not available	

In this plan it is applied in cases of solar thermal system in combination with boiler and other alternative source of non-constant capacity (e.g. fireplace) for charging the water of the store.

The device undertakes via differential control to charge the store (Differential No1 and relay R1).

At the same time, the alternative source is monitored so that it is stored again by differential control in the store, available energy via differential No2 and relay R2.

If the solar activity is not enough, the appliance activates the main auxiliary source (boiler) via relay R3.

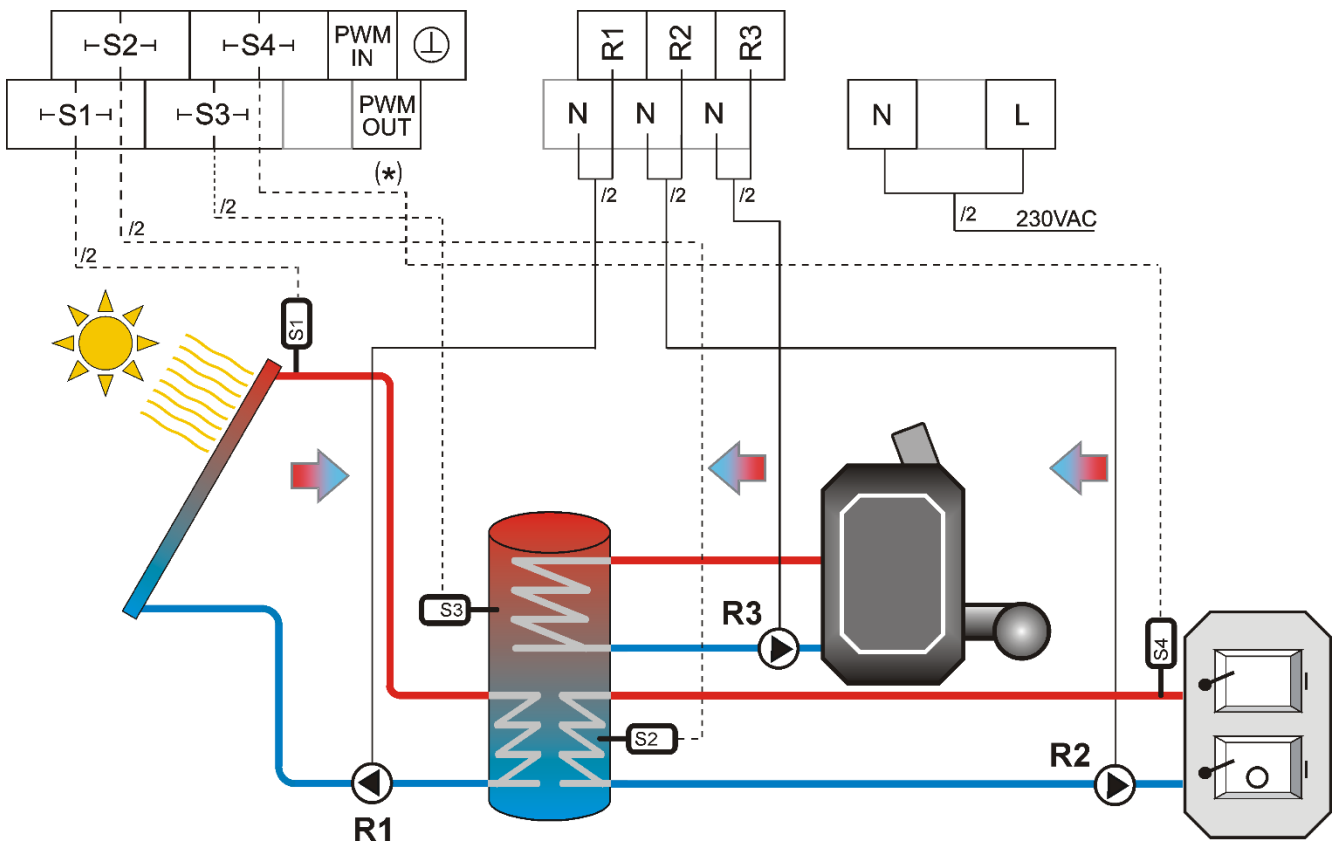

(*) the connections of the PWM cable of the circulator are described in the section "Electrical connections".

Plan No20

Sensors	Control unit	Relationship	Exit
S1	Differential No1		R1
S2			
S1	Differential No2		R2
S4			
Operation			
Thermal disinfection		Available (active via R3)	
Heat rejection		Not available	

In this design priority is the quick heating of the right-hand store. When it has been sufficiently heated, the energy is directed to the left-hand store.

It includes a differential thermostat function to charge the right-hand store through the collector circulator activated by relay R1.

The left-hand store is charged by differential control via the R1 circulator and the activated valve from relay R2.

If the solar activity is not enough to charge the right-hand store, the auxiliary source is activated via relay R3.

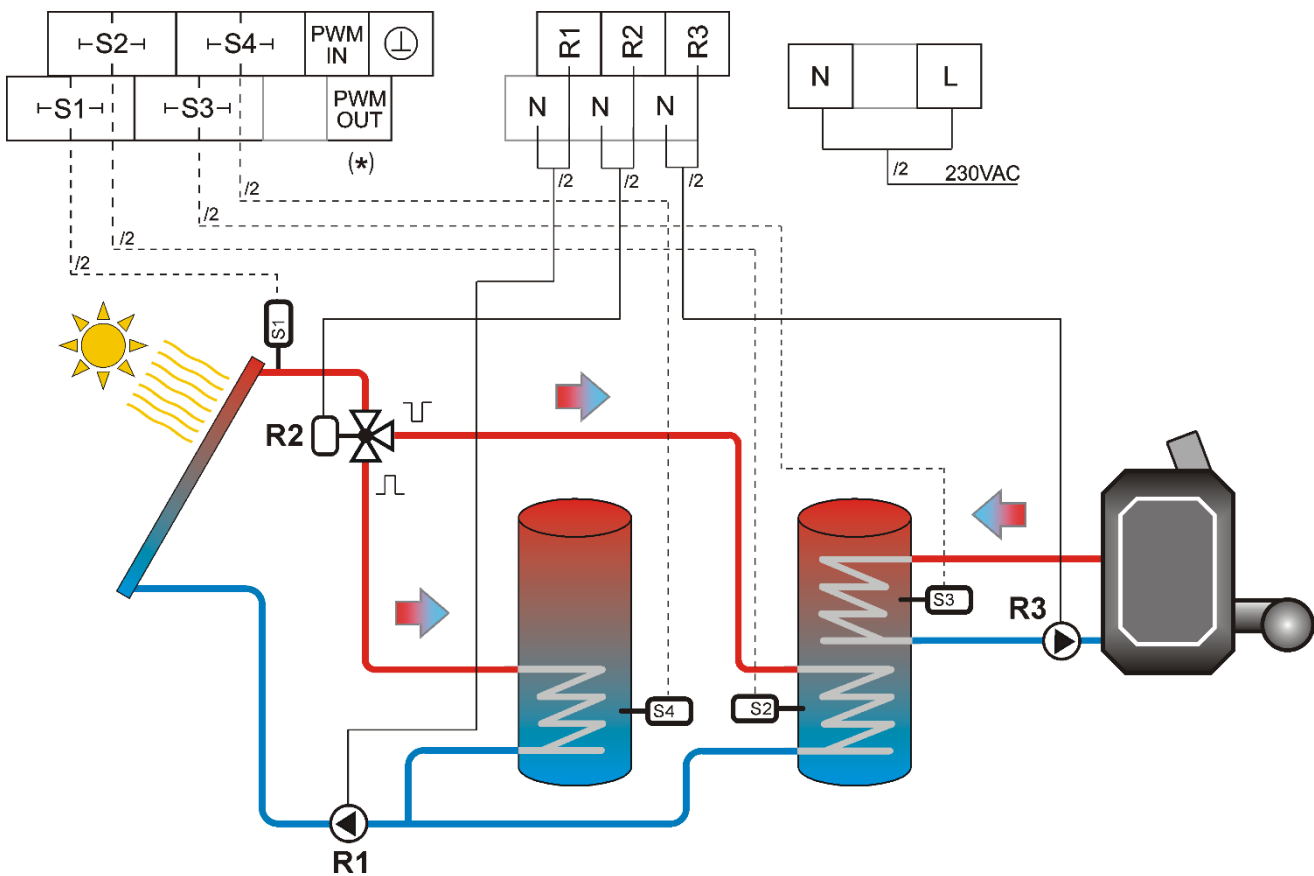

(*) the connections of the PWM cable of the circulator are described in the section "Electrical connections".

Terms of use



Copying and reprinting of drawings, photographs and text of the manual without the consent of the company is prohibited.



Charmeg, konigsol, AirLink, RotorFlex are registered names that protected under trademark law.



Wilo, Grundfos are registered names of other companies.

Support



Attaleias 145, Nikaia, Athens, Greece, 184 53

Tel. +30 210 56 93 111

Fax. +30 210 56 93093

info@charmeg.gr

This product is made of materials that can be recycled and reused in accordance with European Directive 2002/96/EC.

Please be informed about the local collection system for electrical and electronic products and do not dispose of old products with your household waste.

Proper disposal helps to prevent negative effects on the environment and human health.



Notes



145 Attaleias str., Nikea, Athens P.C GR184 53

Tel. +30 210 56 93 111

Fax. +30 210 56 93 093

info@charmeg.gr

www.charmeg.gr